



Standard Practice for Specimen Preparation for Determination of Linear Thermal Expansion of Vitreous Glass Enamels and Glass Enamel Frits by the Dilatometer Method¹

This standard is issued under the fixed designation C 824; the number immediately following the designation indicates the year of original adoption or, in the case of revision, the year of last revision. A number in parentheses indicates the year of last reapproval. A superscript epsilon (ϵ) indicates an editorial change since the last revision or reapproval.

1. Scope

1.1 This practice covers the preparation of vitreous glass enamels and glass enamel frit specimens for the measurement of linear thermal expansion using Test Method E 228.

1.2 The values stated in SI units are to be regarded as the standard. The values given in parentheses are for information only.

1.3 *This standard does not purport to address all of the safety concerns, if any, associated with its use. It is the responsibility of the user of this standard to establish appropriate safety and health practices and determine the applicability of regulatory limitations prior to use.* For specific hazard statements, see Section 6.

2. Referenced Documents

2.1 ASTM Standards:

E 228 Test Method for Linear Thermal Expansion of Solid Materials With a Vitreous Silica Dilatometer²

3. Significance and Use

3.1 The dilatometer method of measuring linear thermal expansion of vitreous glass enamels and glass enamel frits has the advantage of simplicity, lends itself to automatic, self-recording arrangements, and requires test specimens of simple configuration.

4. Apparatus

4.1 *Powder Pressing Die*, whose top and bottom sections are free to move such that density variations within the bar are minimized (see Fig. 1).

4.2 Hydraulic Press.

4.3 *Furnace*, for firing test specimen, electrically heated and controlled to a minimum rate of heating of 1°C/min from room temperature to the maximum temperature of the test. It shall be so designed that the temperature variation over the length of the test specimen shall be less than 2°C during the entire range of heating.

¹ This practice is under the jurisdiction of ASTM Committee C-14 on Glass and Glass Products, and is the direct responsibility of Subcommittee C14.10 on glass Decoration.

Current edition approved Sept. 15, 1991. Published January 1992. Originally published as C 824 – 76. Last previous edition C 824 – 81 (1988).

² *Annual Book of ASTM Standards*, Vol 14.02.

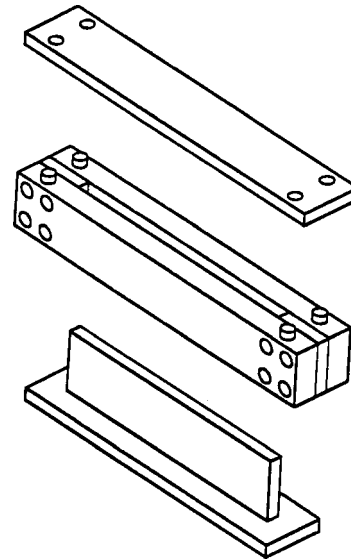

NOTE 1—Material: No. 316 stainless steel.

FIG. 1 Powder Pressing Die

4.4 *Scale or Caliper*, capable of measuring the length of the test specimen to an accuracy of 0.1 %.

5. Reagents and Materials

5.1 *Hydroxypropyl Cellulose Solution in Water* (1 weight%).

5.2 *Powder Sample*.

6. Hazards

6.1 Appropriate ventilation should be provided when handling powdered frits or enamels containing toxic ingredients.

6.2 Ingestion or inhalation of test materials should be avoided. Protective clothing such as gloves, respirators, etc., may be advisable. If ingestion occurs, seek medical attention immediately.

6.3 Caution should be exercised when placing specimens in furnaces. Tongs and insulated gloves should be used. To avoid accidental contact and serious thermal burns, care should be taken to guard hot-fired specimens while they are being cooled.

7. Test Specimen Preparation

7.1 Collect vitreous glass enamel or glass enamel frit

particles within the 60 to 200 mesh particle size range and combine with 0.5 to 1.0 weight % of the hydroxypropyl cellulose solution.

7.2 Using the die in 4.1 and the hydraulic press in 4.2, press the powder prepared in 7.1 at 34 MPa (5000 psi) into a bar consistent with the dimensional guidelines found in Test Method E 228.

7.3 Fire and anneal the test specimen prepared in 7.2 using a time/temperature cycle consistent with that used commer-

cially for the vitreous glass enamel or glass enamel frit involved.

7.4 The ends of the fired test specimen shall conform to the guidelines given in Test Method E 228.

7.5 Measure the length of the test specimen to an accuracy of 0.1 % with the test specimen at a temperature equivalent to the temperature of the dilatometer at the initiation of the test procedure (normally room temperature).

The American Society for Testing and Materials takes no position respecting the validity of any patent rights asserted in connection with any item mentioned in this standard. Users of this standard are expressly advised that determination of the validity of any such patent rights, and the risk of infringement of such rights, are entirely their own responsibility.

This standard is subject to revision at any time by the responsible technical committee and must be reviewed every five years and if not revised, either reapproved or withdrawn. Your comments are invited either for revision of this standard or for additional standards and should be addressed to ASTM Headquarters. Your comments will receive careful consideration at a meeting of the responsible technical committee, which you may attend. If you feel that your comments have not received a fair hearing you should make your views known to the ASTM Committee on Standards, at the address shown below.

This standard is copyrighted by ASTM, 100 Barr Harbor Drive, PO Box C700, West Conshohocken, PA 19428-2959, United States. Individual reprints (single or multiple copies) of this standard may be obtained by contacting ASTM at the above address or at 610-832-9585 (phone), 610-832-9555 (fax), or service@astm.org (e-mail); or through the ASTM website (www.astm.org).