



Standard Test Method for Lead and Cadmium Release from Porcelain Enamel Surfaces¹

This standard is issued under the fixed designation C 872; the number immediately following the designation indicates the year of original adoption or, in the case of revision, the year of last revision. A number in parentheses indicates the year of last reapproval. A superscript epsilon (ϵ) indicates an editorial change since the last revision or reapproval.

1. Scope

1.1 This test method covers the precise determination of lead and cadmium extracted by acetic acid from porcelain enamel surfaces.

1.2 Values stated in SI units are to be regarded as the standard. Inch-pound units are given for information only.

1.3 *This standard does not purport to address all of the safety concerns, if any, associated with its use. It is the responsibility of the user of this standard to establish appropriate safety and health practices and determine the applicability of regulatory limitations prior to use.*

2. Referenced Documents

2.1 *ASTM Standards:*

C 738 Test Method for Lead and Cadmium Extracted from Glazed Ceramic Surfaces²

D 1193 Specification for Reagent Water³

3. Summary of Test Method

3.1 The lead and cadmium extracted from the article under test by acetic acid at 20 to 24°C (68 to 75°F) after 24 h of leaching are measured by atomic absorption spectrophotometry using a specific hollow cathode lamp for lead and cadmium respectively.

4. Significance and Use

4.1 The determination of lead and cadmium release from porcelain enamel surfaces was formerly of interest only to manufacturers of porcelain enamel cookware and similar food service products. Food contact surfaces of these container-type products have been evaluated using a test procedure similar to Test Method C 738. Recently, however, there has been a need to measure lead and cadmium release from flat or curved porcelain enamel surfaces that are not capable of being evaluated by a test similar to Test Method C 738.

5. Interferences

5.1 Since a specific hollow cathode lamp for lead and cadmium is used, there are no interferences.

6. Apparatus

6.1 *Atomic Absorption Spectrophotometer*, equipped with a 102-mm (4-in.) single slot or Boling burner head and digital concentration readout attachment (DCR) if available.⁴ This instrument should have a sensitivity of about 0.5 mg/L of lead for 1 % absorption and a sensitivity of about 0.03 mg/L of cadmium for 1 % absorption. The operating conditions as specified in the instrument manufacturer's analytical methods manual shall be used.

NOTE 1—ppm, mg/L, and $\mu\text{g/mL}$ are equivalent units.

6.2 *Hollow Cathode Lead Lamp*, with wavelength set at 283.3 or 217.0 nm.

6.3 *Hollow Cathode Cadmium Lamp*, with wavelength set at 228.8 nm.

6.4 *Glassware* of chemically resistant borosilicate glass, to make reagents and solutions.

6.5 *Test Cell*, suitable for the containment of the leaching solution on a flat porcelain enamel surface. A cell that has proved suitable for this purpose is shown in Fig. 1.

7. Reagents

7.1 *Purity of Reagents*—Reagent grade chemicals shall be used in all tests. Unless otherwise indicated, it is intended that all reagents shall conform to the specifications of the Committee on Analytical Reagents of the American Chemical Society, where such specifications are available.⁵ Other grades may be used provided it is first ascertained that the reagent is of sufficiently high purity to permit its use without lessening the accuracy of the determination.

7.2 *Purity of Water*—Unless otherwise indicated, references to water shall be understood to mean distilled water. (See Specification D 1193.)

¹ This test method is under the jurisdiction of ASTM Committee B-8 on Metallic and Inorganic Coatings and is the direct responsibility of Subcommittee B08.12 on Materials for Porcelain Enamel and Ceramic-Metal Systems.

Current edition approved Sept. 29, 1989. Published April 1990. Originally published as C 872 – 77. Last previous edition C 872 – 83.

² *Annual Book of ASTM Standards*, Vol 15.02.

³ *Annual Book of ASTM Standards*, Vol 11.01.

⁴ Perkin-Elmer model 303 and Jarrell-Ash model 82-546 have been found suitable for this determination.

⁵ *Reagent Chemicals, American Chemical Society Specifications*, American Chemical Society, Washington, DC. For suggestions on the testing of reagents not listed by the American Chemical Society, see *Analar Standards for Laboratory Chemicals*, BDH Ltd., Poole, Dorset, U.K., and the *United States Pharmacopeia and National Formulary*, U.S. Pharmaceutical Convention, Inc. (USPC), Rockville, MD.

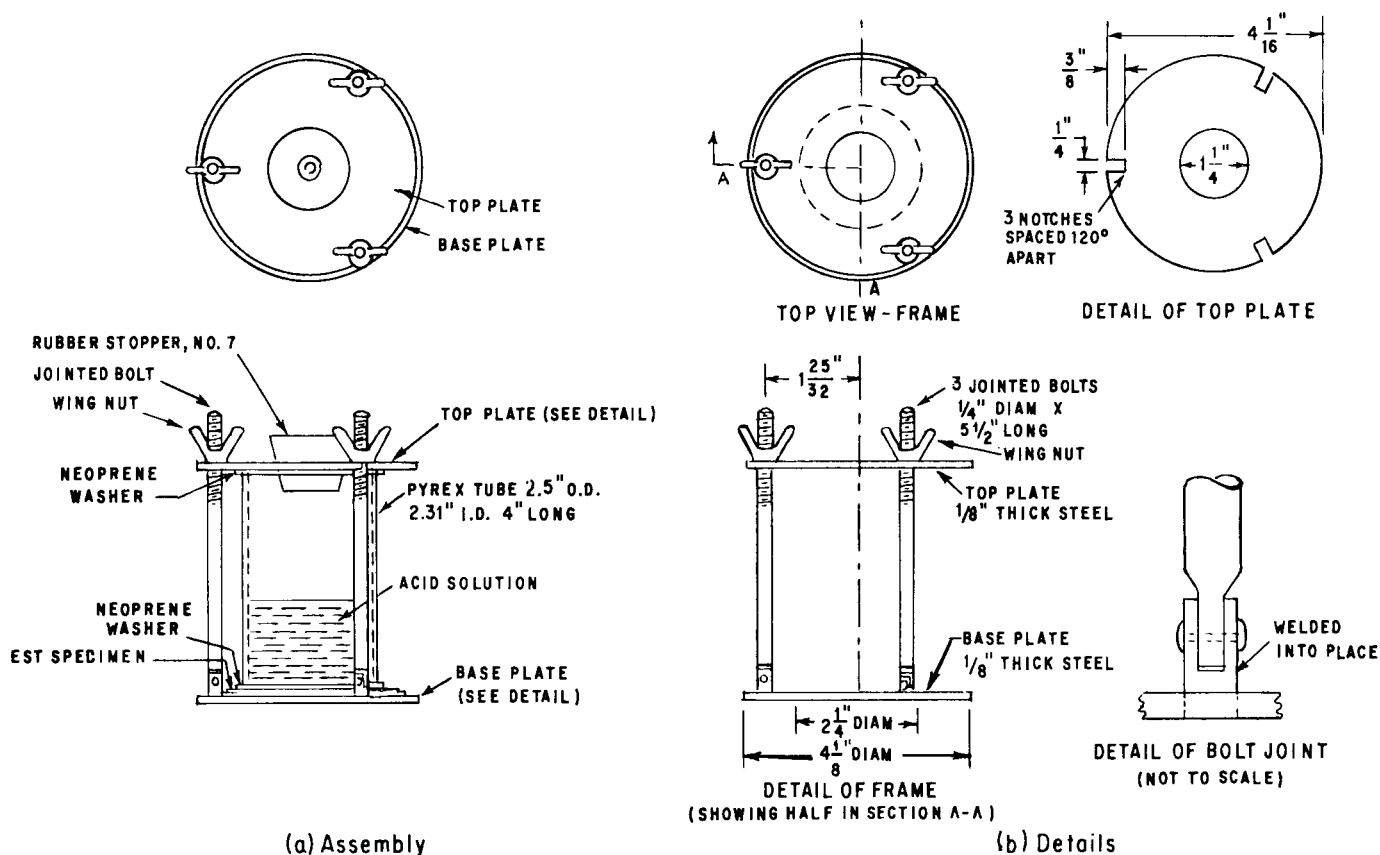

Metric Equivalents for Apparatus Dimensions (Fig. 1)

in.	mm
1/8	3.2
1/4	6.4
3/8	9.5
1 1/4	31.8
1 25/32	45.2
2 1/4	57.2
2.31	58.7
2.5	63.5
4	101.6
4 1/16	103.2
4 1/8	104.8
5 1/2	139.7

FIG. 1 Suitable Test Cell

7.3 *Acetic Acid* (4 % by volume)—Mix 1 volume of glacial acetic acid with 24 volumes of water.

NOTE 2—A reagent blank shall be run each time a 4 % acid solution is prepared.

7.4 *Detergent Rinse*—Add 15 g of suitable alkaline detergent⁶ to 1 gal (3.79 L) of lukewarm tap water.

7.5 *Lead Nitrate Solution* (1000 mg Pb/L)—Dissolve 1.598 g of lead nitrate (Pb(NO₃)₂) in 4 % acetic acid and dilute to 1 L with 4 % acetic acid. Commercially available standard lead solutions may also be used.

7.6 *Hydrochloric Acid* (1 % by weight)—Mix 1 volume of

concentrated hydrochloric acid (HCl sp gr 1.19) with 37 volumes of water.

7.7 *Cadmium* (1000 mg Cd/L)—Dissolve 0.500 g of cadmium metal in 250 mL of hot 1 % HCl (see 7.6), cool, and dilute to 500 mL with 1 % HCl. Commercially available standard cadmium solutions may also be used.

8. Samples

8.1 *Test Specimens*—Specimens may be cut from production parts or may be prepared on metal blanks under production conditions. Tests may be made on finished parts where flat horizontal surfaces are available.

8.2 *Size*—The size of the test area shall be approximately 26 cm² (4 in.²).

⁶ A suitable detergent is Calgonite, manufactured by the Calgon Corp., Box 1436, Pittsburgh, PA 15230, and is available in most supermarkets.

9. Procedure

9.1 *Preparation of Sample*—Take, at random, three identical units and cleanse each with the detergent rinse. Then rinse with tap water followed by distilled water. Dry the specimens and fit into a suitable test cell similar to that shown in Fig. 1, or place a weighted cell onto a flat surface of a production part. Fill each unit with 4 % acetic acid, with a maximum of 40 mL for each 6.45 cm² (1 in.²) of exposed surface. Record the volume of acid for each unit in the sample. Cover each unit with clear, colorless glass plate to prevent evaporation of the solution, avoiding contact between the cover and surface of the leaching solution, and expose to normal laboratory light for 8 to 10 h during the leaching period. Let the solution stand for 24 h at room temperature (20 to 24°C (68 to 75°F)).

9.2 Preparation of Standards:

9.2.1 *Lead Standards*—Dilute lead nitrate solution (see 7.5) with acetic acid (see 7.3) to obtain working standards having final concentrations of 0, 5, 10, 15, and 20 mg Pb/L.

9.2.2 *Cadmium Standards*—Dilute cadmium stock solution (see 7.7) with acetic acid (see 7.3) to obtain working standards having final concentrations of 0.0, 0.3, 0.5, 1, 1.5, and 2.0 µg Cd/mL.

9.3 *Determination of Lead by Atomic Absorption*—Stir the sample (leaching) solution and pour off a portion into a clean flask. Using the atomic absorption spectrophotometer (6.1) and hollow cathode lamp (6.2), concomitantly determine the absorbance of the lead working standards (9.2.1) and sample (leaching) solutions, diluting the latter with 4 % acetic acid if required (if solution contains over 20 mg/L). Concentrate samples containing less than 1 ppm lead by accurately transferring a minimum of 50.0 mL of solution to a 250-mL beaker and evaporating to dryness on a steam bath. Dissolve the residue in 4 % acetic acid by adding exactly 0.1 volume of

solution taken for concentration, cover with a watch glass, and swirl to complete dissolution. Prepare a standard curve of absorbance versus concentration (mg/L). Determine the lead content (mg Pb/L) of sample (leaching) solution from the standard curve.

NOTE 3—If a digital concentration readout is used, the standard curve is not necessary. However, standards bracketing the solution under test should be used.

9.4 *Determination of Cadmium by Atomic Absorption Spectrophotometry*—Proceed as in 9.3 using the cadmium hollow-cathode lamp (see 6.3) and cadmium standards (see 9.2.2). If the sample (leaching) solutions contain more than 2 mg Cd/L, dilute with 4 % acetic acid. Concentrate samples containing less than 0.1 mg/L as in 9.3.

10. Report

10.1 Report the type of units tested, the volume of acid used, and the lead and cadmium, respectively, leached in micrograms per millilitre for each unit tested.

NOTE 4—As indicated in Section 1, this procedure covers the extraction and measurement of lead and cadmium. It is general in that it does not recommend specific sample unit types. For special end uses, as for example, process control or interlaboratory testing, a specific size and type of sample unit should be used.

11. Precision and Bias

11.1 Precision of the analytical method for a single or multiple operator within a single laboratory is within the sensitivity of the atomic absorption spectrophotometer.

11.2 The precision and bias between laboratories is dependent upon the ability to obtain representative samples of the statistical universe being sampled.

The American Society for Testing and Materials takes no position respecting the validity of any patent rights asserted in connection with any item mentioned in this standard. Users of this standard are expressly advised that determination of the validity of any such patent rights, and the risk of infringement of such rights, are entirely their own responsibility.

This standard is subject to revision at any time by the responsible technical committee and must be reviewed every five years and if not revised, either reapproved or withdrawn. Your comments are invited either for revision of this standard or for additional standards and should be addressed to ASTM Headquarters. Your comments will receive careful consideration at a meeting of the responsible technical committee, which you may attend. If you feel that your comments have not received a fair hearing you should make your views known to the ASTM Committee on Standards, at the address shown below.

This standard is copyrighted by ASTM, 100 Barr Harbor Drive, PO Box C700, West Conshohocken, PA 19428-2959, United States. Individual reprints (single or multiple copies) of this standard may be obtained by contacting ASTM at the above address or at 610-832-9585 (phone), 610-832-9555 (fax), or service@astm.org (e-mail); or through the ASTM website (www.astm.org).