



Standard Test Methods for Determination of Nickel, Vanadium, Iron, and Sodium in Crude Oils and Residual Fuels by Flame Atomic Absorption Spectrometry¹

This standard is issued under the fixed designation D 5863; the number immediately following the designation indicates the year of original adoption or, in the case of revision, the year of last revision. A number in parentheses indicates the year of last reapproval. A superscript epsilon (ϵ) indicates an editorial change since the last revision or reapproval.

1. Scope

1.1 These test methods cover the determination of nickel, vanadium, iron, and sodium in crude oils and residual fuels by flame atomic absorption spectrometry (AAS). Two different test methods are presented.

1.2 *Test Method A, Sections 7–12*—Flame AAS is used to analyze a sample that is decomposed with acid for the determination of total Ni, V, and Fe.

1.3 *Test Method B, Sections 13–17*—Flame AAS is used to analyze a sample diluted with an organic solvent for the determination of Ni, V, and Na. This test method uses oil-soluble metals for calibration to determine dissolved metals and does not purport to quantitatively determine nor detect insoluble particulates. Hence, this test method may underestimate the metal content, especially sodium, present as inorganic sodium salts.

1.4 The concentration ranges covered by these test methods are determined by the sensitivity of the instruments, the amount of sample taken for analysis, and the dilution volume. A specific statement is given in Note 1.

1.5 For each element, each test method has its own unique precision. The user can select the appropriate test method based on the precision required for the specific analysis.

1.6 The values stated in SI units are to be regarded as the standard. The values given in parentheses are for information only.

1.7 *This standard does not purport to address all of the safety concerns, if any, associated with its use. It is the responsibility of the user of this standard to establish appropriate safety and health practices and determine the applicability of regulatory limitations prior to use.* Specific warning statements are given in 7.1, 8.2, 8.5, 10.2, 10.4, and 15.1.

¹ These test methods are under the jurisdiction of ASTM Committee D02 on Petroleum Products and Lubricants and are the direct responsibility of Subcommittee D02.03 on Elemental Analysis.

Current edition approved Nov. 10, 2000. Published November 2000. Originally published as D 5863 – 95. Last previous edition D 5863 – 00.

2. Referenced Documents

2.1 *ASTM Standards:*

D 1193 Specification for Reagent Water²

D 4057 Practice for Manual Sampling of Petroleum and Petroleum Products³

D 4177 Practice for Automatic Sampling of Petroleum and Petroleum Products³

D 6299 Practice for Applying Statistical Quality Assurance Techniques to Evaluate Analytical Measurement System Performance⁴

3. Summary of Test Methods

3.1 *Test Method A*—One to twenty grams of sample are weighed into a beaker and decomposed with concentrated sulfuric acid by heating to dryness. The residual carbon is burned off by heating at 525°C in a muffle furnace. The inorganic residue is digested in dilute nitric acid, evaporated to incipient dryness, dissolved in dilute nitric and made up to volume with dilute nitric acid. Interference suppressant is added to the dilute nitric acid solution. The solution is nebulized into the flame of an atomic absorption spectrometer. A nitrous oxide/acetylene flame is used for vanadium and an air/acetylene flame is used for nickel and iron. The instrument is calibrated with matrix-matched standard solutions. The measured absorption intensities are related to concentrations by the appropriate use of calibration data.

3.2 *Test Method B*—Sample is diluted with an organic solvent to give a test solution containing either 5 % (m/m) or 20 % (m/m) sample. The recommended sample concentration is dependent on the concentrations of the analytes in the sample. For the determination of vanadium, interference suppressant is added to the test solution. The test solution is nebulized into the flame of an atomic absorption spectrometer. A nitrous oxide/acetylene flame is used for vanadium and an

² *Annual Book of ASTM Standards*, Vol 11.01.

³ *Annual Book of ASTM Standards*, Vol 05.02.

⁴ *Annual Book of ASTM Standards*, Vol 05.03.

air/acetylene flame is used for nickel and sodium. The measured absorption intensities are related to concentrations by the appropriate use of calibration data.

4. Significance and Use

4.1 When fuels are combusted, metals present in the fuels can form low melting compounds that are corrosive to metal parts. Metals present at trace levels in petroleum can deactivate catalysts during processing. These test methods provide a means of quantitatively determining the concentrations of vanadium, nickel, iron, and sodium. Thus, these test methods can be used to aid in determining the quality and value of the crude oil and residual oil.

5. Purity of Reagents

5.1 Reagent grade chemicals shall be used for all tests. Unless otherwise indicated, it is intended that all reagents conform to the specifications of the Committee on Analytical Reagents of the American Chemical Society where such specifications are available.⁵ Other grades may be used, provided it is first ascertained that the reagent is of sufficiently high purity to permit its use without lessening the accuracy of the determination.

5.2 When determining metals at concentrations less than 1 mg/kg, use ultra-pure grade reagents.

5.3 *Purity of Water*—Unless otherwise indicated, reference to water shall be understood to mean reagent water conforming to Type II of Specification D 1193.

6. Sampling and Sample Handling

6.1 The objective of sampling is to obtain a sample for testing purposes that is representative of the entire quantity. Only representative samples obtained as specified in Practices D 4057 and D 4177 shall be used. Do not fill the sample container more than two-thirds full

6.2 Prior to weighing, stir the sample and then shake the sample in its container. If the sample does not readily flow at room temperature, heat the sample to a sufficiently high and safe temperature to ensure adequate fluidity.

TEST METHOD A—FLAME ATOMIC ABSORPTION AFTER ACID DECOMPOSITION OF THE SAMPLE

7. Apparatus

7.1 *Atomic Absorption Spectrometer*, complete instrument with hollow cathode lamps and burners with gas supplies to support air-acetylene and nitrous oxide-acetylene flames (**Warning**—Hazardous. Potentially toxic and explosive. Refer to the manufacturer's instrument manual for associated safety hazards.).

⁵ *Reagent Chemicals, American Chemical Society Specifications*, American Chemical Society, Washington, DC. For suggestions on the testing of reagents not listed by the American Chemical Society, see *Analar Standards for Laboratory Chemicals*, BDH Ltd., Poole, Dorset, U.K., and the *United States Pharmacopeia and National Formulary*, U.S. Pharmacopeial Convention, Inc. (USPC), Rockville, MD.

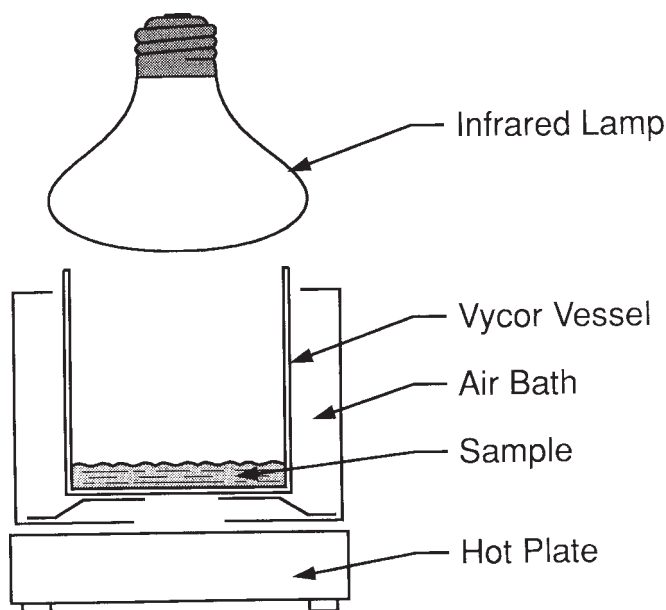

FIG. 1 Decomposition Apparatus

7.2 *Sample Decomposition Apparatus (optional)*—This apparatus is described in Fig. 1. It consists of a borosilicate glass 400-mL beaker for the test solution, an air bath (Fig. 2) that rests on a hot plate and a 250 W infrared lamp supported 2.5 cm above the air bath. A variable transformer controls the voltage applied to the lamp.

7.3 *Glassware*—Borosilicate glass 400-mL beakers, volumetric flasks of various capacities and pipettes of various capacities. When determining concentrations below 1 mg/kg, all glassware must be thoroughly cleaned (or soaked overnight) with 5 % HNO₃ and rinsed five times with water.

7.4 *Electric Muffle Furnace*, capable of maintaining 525 ± 25°C and sufficiently large to accommodate 400-mL beakers. The capability of an oxygen bleed is advantageous and optional.

7.5 *Steam Bath*.

7.6 *Temperature Controlled Hot Plate*, (optional).

7.7 *Drying Oven*, (optional), explosion-proof, if used to heat crude oils to obtain fluidity.

8. Reagents

8.1 *Aqueous Standard Solutions*—Individual aqueous standards with 1000 mg/kg concentrations of vanadium, nickel, and iron, purchased or prepared in acid matrix to ensure stability.

8.2 *Nitric Acid*—Concentrated nitric acid, HNO₃ (**Warning**—Poison, oxidizer. Causes severe burns. Harmful or fatal if swallowed or inhaled.).

8.3 *Nitric Acid 50 % (V/V)*—Carefully add, with stirring, one volume of concentrated nitric acid to one volume of water.

8.4 *Dilute Nitric Acid, 5 % (V/V)*—Carefully add, with stirring, one volume of concentrated nitric acid to 19 volumes of water.

8.5 *Sulfuric Acid*—Concentrated sulfuric acid, H₂SO₄ (**Warning**—Poison, oxidizer. Causes severe burns. Harmful or fatal if swallowed or inhaled.).

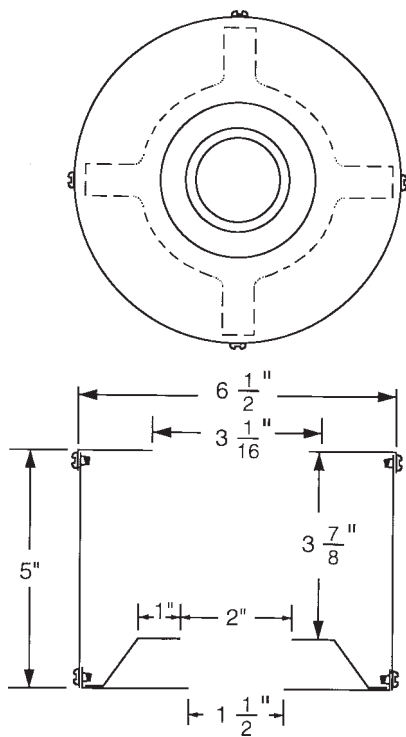

Note—All parts 16 gage (1.5 mm, 0.060 in.) aluminum. All dimensions are in inches.

Metric Equivalents			
in.	mm	in.	mm
1	25.4	3/8	98.4
1 1/2	38.1	5	127
2	50.8	6 1/2	165.1
3 1/16	77.8		

FIG. 2 Air Bath

8.6 Aluminum Nitrate, $\text{Al}(\text{NO}_3)_3 \cdot 9\text{HOH}$.

8.7 Potassium Nitrate, KNO_3 .

9. Preparation of Standards

9.1 *Multi-Element Standard*—Using the aqueous standard solutions, prepare a multi-element standard containing 100 mg/kg each of vanadium, nickel, and iron. Standards should be prepared to ensure accuracy and stability and should be stored in clean containers to safeguard against physical degradation.

9.2 *Working Standards*—Prepare at least two working standards to cover the concentration ranges specified in Table 1. For vanadium, add the specified interference suppressant. Each working standard must contain 5 % (V/V) nitric acid. Standards should be prepared to ensure accuracy and stability and should be stored in clean containers to safeguard against physical degradation.

9.3 *Standard Blank*, the standard blank contains 5 % (V/V) nitric acid and any interference suppressant specified in Table 1.

9.4 *Check Standard*—Prepare a calibration check standard in the same way as the working standards and at analyte concentrations that are typical of the specimens being analyzed.

TABLE 1 AAS Conditions for the Determination of Vanadium, Nickel, and Iron Following Acid Sample Decomposition

Element	Wavelength, nm	Concentration Range, $\mu\text{g}/\text{mL}$	Interference Suppressant	Flame
Vanadium	318.4	0.5–20	250 $\mu\text{g}/\text{mL}$ Al, $\text{Al}(\text{NO}_3)_3$ in 5 % (V/V) HNO_3	$\text{N}_2\text{O}-\text{C}_2\text{H}_2$
Nickel	232.0	0.5–20	None	Air- C_2H_2
Iron	248.3	3.0–10	None	Air- C_2H_2

10. Preparation of Test Solutions

10.1 Into a beaker, weigh an amount of sample estimated to contain between 0.0025 and 0.12 mg of each metal to be determined. A typical mass is 10 g. Add 0.5 mL of H_2SO_4 for each gram of sample.

NOTE 1—If it is desired to extend the lower concentration limits of the test method, it is recommended that the decomposition be done in 10-g increments up to a maximum of 100 g. It is not necessary to destroy all the organic matter each time before adding additional amounts of the sample and acid. When it is desired to determine higher concentrations, reduce the sample size accordingly.

10.2 At the same time prepare reagent blanks using the same amount of sulfuric acid as used for sample decomposition. Reagent blanks should be carried through the same procedure as the samples. **Warning**—Reagent blanks are critical when determining concentrations below 1 mg/kg. To simplify the analysis, use the same volume of acid and the same dilutions as used for the samples. For example, if 20 g of sample is being decomposed, use 10 mL of sulfuric acid for the reagent blank.

10.3 The use of the air bath apparatus (Fig. 2) is optional. Place the beaker in the air bath, which is located in the hood. The hot plate is off at this time. Heat gently from the top with the infrared lamp (Fig. 1) while stirring the test solution with a glass rod. As decomposition proceeds (indicated by a frothing and foaming), control the heat of the infrared lamp to maintain steady evolution of fumes. Give constant attention to each sample mixture until all risk of spattering and foaming is past. Then, gradually increase the temperature of both the hot plate and lamp until the sample is reduced to a carbonaceous ash.

10.4 If the air bath apparatus is not used, heat the sample and acid on a temperature controlled hot plate. As described in 10.3, monitor the decomposition reaction and adjust the temperature of the hot plate accordingly. **Warning**—Hot fuming concentrated sulfuric acid is very corrosive and a strong oxidizing acid. The analyst should work in a well-ventilated hood and wear rubber gloves and a suitable face shield to protect against spattering acid.

10.5 Place the sample in the muffle furnace maintained at $525 \pm 25^\circ\text{C}$. Optionally, introduce a gentle stream of oxygen into the furnace to expedite oxidation. Continue to heat until the carbon is completely removed.

10.6 Dissolve the inorganic residue by washing down the wall of the beaker with about 10 mL of the 1 + 1 HNO_3 . Digest on a steam bath for 15 to 30 min. Transfer to a hot plate and gently evaporate to incipient dryness.

10.7 Wash down the wall of the beaker with about 10 mL of dilute nitric acid (5 % V/V). Digest on the steam bath until all

salts are dissolved. Allow to cool. Transfer quantitatively to a volumetric flask of suitable volume and make up to volume with dilute nitric acid. This is the test solution.

10.8 Pipette aliquots of the test solution into two separate volumetric flasks. Retain one flask for the determination of nickel and iron. To the other flask add aluminum interference suppressant for vanadium determination (refer to Table 1) and dilute up to mark with dilute nitric acid (5 % V/V). Similarly, prepare a reagent blank solution for vanadium analysis.

11. Preparation of Apparatus

11.1 Consult the manufacturer's instructions for the operation of the atomic absorption spectrometer. This test method assumes that good operating procedures are followed. Design differences between spectrometers make it impractical to exactly specify required instrument settings.

11.2 Set up the instrument to determine each analyte sequentially.

12. Calibration and Analysis

12.1 For each analyte in turn, perform the following operation.

12.2 Nebulize the appropriate blank standard and zero the instrument.

12.3 Nebulize the working standards, determine the absorbance and construct a calibration curve of absorbance versus analyte concentration utilizing the instrument's concentration mode if available, otherwise plot these values.

12.4 Use the check standard to determine if the calibration for each analyte is accurate. If the results obtained on the check standard are not within $\pm 5\%$ of the expected concentration for each analyte, take corrective action and repeat the calibration.

12.5 Nebulize the test solutions and measure and record the absorbance. If appropriate, blank correct this absorbance by subtracting the reagent blank absorbance.

12.6 After measuring absorbances for a test solution, check the blank standard. If this does not read zero, check the system and then repeat steps 12.2-12.5.

12.7 Test solutions that give absorbances greater than that obtained with the most concentrated working standard must be diluted. The dilution must contain interference suppressant at the specified concentrations.

13. Quality Assurance/Quality Control (QA/QC)

13.1 Confirm the performance of the instrument and the test procedure by analyzing a control QC sample.

13.1.1 When QA/QC protocols are already established in the testing facility, these may be used to confirm the reliability of the test result.

13.1.2 When there is no QA/QC protocol established in the testing facility, Appendix X1 can be used as the QA/QC protocol.

13.2 Users of this test method are advised that in contractual agreements, one or more of the contracting parties can and may make Appendix X1 a mandatory practice.

TABLE 2 AAS Conditions for the Determination of Vanadium, Nickel, and Sodium Following Solvent Dilution of the Sample

Element	Wavelength, nm	Concentration Range, mg/kg	Interference Suppressant	Flame
Vanadium	318.4	0.5–15	15 mg/kg Al ^A	N ₂ O-C ₂ H ₂
Nickel	232.0	0.5–20	None	Air-C ₂ H ₂
Sodium	589.0	0.1–5	None	Air-C ₂ H ₂

^APrepared from an organometallic standard, mineral oil, and dilution solvent.

TEST METHOD B—FLAME ATOMIC ABSORPTION WITH AN ORGANIC SOLVENT TEST SOLUTION

14. Apparatus

14.1 Refer to Section 7.1.

14.2 *Test Solution Containers*—Glass or plastic vials or bottles, with screw caps and a capacity of between 50 to 100 mL. Glass bottles of 100-mL capacity are satisfactory.

15. Reagents

15.1 *Dilution Solvent*—Mixed xylenes, o-xylene, tetralin and mixed paraffin-aromatic solvents are satisfactory (**Warning**—Combustible. Vapor harmful.). Solvent purity can affect analytical accuracy when the sample contains low concentrations (typically, a few mg/kg) of the analytes.

15.2 *Mineral Oil*—A high-purity oil such as U.S.P. white oil.

15.3 *Organometallic Standards*—Pre-prepared multi-element concentrates containing 100 mg/kg concentrations of each element are satisfactory.⁶

16. Preparation of Standards and Test Solutions

16.1 *Test Solution*—Weigh a portion of well-mixed sample into a container and add solvent to achieve a sample concentration of either 5 % (m/m) or 20 % (m/m). Mix well. If the concentration of V, Ni, or Na in the sample exceeds 20 mg/kg, the analysis for that element is performed on a test solution containing 5 % (m/m) sample. For concentrations less than 20 mg/kg, the analysis for that element is performed on a test solution that contains 20 % (m/m) sample.

16.2 *Standards*—If the test solution contains 5 % (m/m) sample, then the corresponding working standards and check standard must contain 5 % (m/m) oil. Similarly, if the test solution contains 20 % (m/m) sample, the standards must contain 20 % (m/m) oil. A consistent dilution factor is necessary so that all aspirated samples and standards will have the same viscosity. This is essential to obtain consistent uptake rates.

16.2.1 *Working Standards*—Prepare a blank (from mineral oil) and three additional working standards (from the organometallic standards) that cover the ranges of concentration specified in Table 2.

16.2.2 *Check Standard*—Using the organometallic standards, mineral oil, and dilution solvent, prepare a check standard to contain analyte concentrations approximately the same as expected in the test solutions.

⁶Standards from the following source have been found satisfactory for this purpose: Conoco, Inc., Conostan Division, P.O. Box 1269, Ponca City, OK 74602.

17. Preparation of Apparatus

17.1 Refer to Section 11.

18. Calibration and Analysis

18.1 Refer to Section 12.

19. Quality Assurance/Quality Control (QA/QC)

19.1 Refer to Section 13.

20. Calculation

20.1 For Test Method A, calculate the concentration of each analyte in the sample using the following equation:

$$\text{analyte concentration, mg/kg} = (C \times V \times F)/W \quad (1)$$

where:

C = concentration of the analyte in the test solution (corrected for the concentration determined in the reagent blank), $\mu\text{g/mL}$,

V = volume of the test solution, mL,

F = dilution factor, volume/volume or mass/mass, and

W = sample mass, g.

20.2 For Test Method B, calculate the concentration of each analyte in the sample using the following equation.

$$\text{analyte concentration, mg/kg} = C \times F \quad (2)$$

where:

C = concentration of the analyte in the test solution, mg/kg, and

F = dilution factor, volume/volume or mass/mass.

21. Report

21.1 Report the following information:

21.1.1 Report concentrations in mg/kg to two significant figures.

22. Precision and Bias ⁷

22.1 *Precision*—The precision of this test method was determined by statistical analysis on interlaboratory test results. For Test Methods A and B, six cooperators participated in the interlaboratory study. Seven samples (four residual oils and three crude oils) comprised the test set. One residual oil was NIST SRM 1618.⁵ One crude oil was NIST SRM 8505.⁸

22.1.1 *Repeatability*—The difference between two test results, obtained by the same operator with the same apparatus under constant operating conditions on identical test materials would, in the long run, in the normal and correct operation of the test method, exceed the values in Table 3 and Table 4 only in one case in twenty.

22.1.2 *Reproducibility*—The difference between two single and independent results, obtained by different operators working in different laboratories on identical test materials, would in

TABLE 3 Repeatability

Element	Concentration Range, mg/kg	Test Method	Repeatability, mg/kg ^A
Vanadium	50–500	A	$1.1X^{0.50}$
		B	$0.13X^{0.92}$
Nickel	10–100	A	$0.20X^{0.65}$
		B	$0.005X^{1.4}$
Iron	3–10	A	0.98
Sodium	1–20	B	$0.12X^\dagger$

^A X = mean concentration, mg/kg.

[†]Editorially corrected.

TABLE 4 Calculated Repeatability (mg/kg) at Selected Concentrations (mg/kg)

Element	Test Method	Concentration				
		1	10	50	100	500
Vanadium	A			7.8	11.0	25.0
	B			4.8	9.0	40.0
Nickel	A		0.89	2.5	4.0	
	B		0.13	1.2	3.2	
Iron	A		0.98			
	B	0.12	1.2			

the long run, in the normal and correct operation of the test method, exceed the values in Table 5 and Table 6 only in one case in twenty.

22.2 *Bias*—Bias was evaluated from results obtained on two NIST samples. For Test Method A, the means of the reported values for V and Ni do not differ from the corresponding expected values by more than the repeatability of the test method. For Test Method B, the mean of the reported values for V does not differ from the corresponding expected value by more than the repeatability of the test method, and the mean of the reported values for Ni is higher than the expected value by an amount approximately equal to twice the repeatability of the test method. Standard reference materials for Fe and Na are not available, so bias was not determined for these elements.

23. Keywords

23.1 atomic absorption spectrometry; AAS; iron; nickel; sodium; vanadium

⁷ Request RR:D02-1351 for interlaboratory study data. Available from ASTM Headquarters.

⁸ Available from the National Institute of Standards and Technology, Gaithersburg, MD 20899.

TABLE 5 Reproducibility

Element	Concentration Range, mg/kg	Test Method	Reproducibility, mg/kg ^A
Vanadium	50–500	A	0.33X ^{0.90}
		B	1.2X ^{0.80}
Nickel	10–100	A	1.3X ^{0.53}
		B	0.06X ^{1.2}
Iron	3–10	A	1.45X ^{0.45}
Sodium	1–20	B	0.69X

^AX = mean concentration, mg/kg.

TABLE 6 Calculated Reproducibility (mg/kg) at Selected Concentrations (mg/kg)

Element	Test Method	Concentration				
		1	10	50	100	500
Vanadium	A			11.0	21.0	89.0
	B			27.0	48.0	170.0
Nickel	A		4.4	10.0	15.0	
	B		0.95	6.6	15.0	
Iron	A		4.1			
Sodium	B	0.69	6.9			

APPENDIXES

(Nonmandatory Information)

X1. GENERIC QUALITY CONTROL STATEMENT FOR D02 TEST METHODS

X1.1 Confirm the performance of the instrument or the test procedure by analyzing a QC sample that is, if possible, representative of the samples typically analyzed.

X1.2 Prior to monitoring the measurement process, the user of the test method needs to determine the average value and control limits of the QC sample (see Test Method D 6299 and *ASTM MNL7*⁹).

X1.3 Record the QC results and analyze by control charts or other statistically equivalent techniques to ascertain the statistical control status of the total test process (see Test Method D 6299 and *MNL7*). Any out-of-control data should trigger investigation for root cause(s). The results of this investigation may not necessarily result in instrument calibration.

X1.4 In the absence of explicit requirements given in the

test method, the frequency of QC testing is dependent on the criticality of the quality being measured, the demonstrated stability of the testing process, and customer requirements. Generally, a QC sample should be analyzed each testing day with routine samples. The QC frequency should be increased if a large number of samples is routinely analyzed. However, when it is demonstrated that the testing is under statistical control, the QC testing frequency may be reduced. The QC sample precision should be periodically checked against the ASTM method precision to ensure data quality.

X1.5 It is recommended that, if possible, the type of QC sample that is regularly tested be representative of the sample routinely analyzed. An ample supply of QC sample material should be available for the intended period of use, and must be homogeneous and stable under the anticipated storage conditions.

X1.6 Refer to relevant documents (see Test Method D 6299 and *ASTM MNL7*) for further guidance on QC and Control charting techniques.

⁹ *ASTM MNL7* “Manual on Presentation of Data Control Chart Analysis, 6th Ed Section 3: Control Chart for Individuals”, available from ASTM Headquarters.

X2. AIDS TO THE ANALYST

X2.1 Employ adequate mixing and sampling procedures for crude and heavy oils. Use paint mixers for mixing of crude oils. Heat heavy oils sufficiently to obtain good fluidity, and then shake vigorously.

X2.2 Use the specified analytical wavelengths because they have been established by experiment to be optimal and free from spectral interferences.

X2.3 Disassemble and clean the burner on a maintenance schedule that is appropriate for the type of samples analyzed.

X2.4 Inspect the nebulizer tubing daily for kinks, restrictions, or cracks. Replace when necessary.

X2.5 Measure the nebulizer uptake rate daily to check for plugging. Clean when the rate is not normal.

X2.6 Calibrate the instrument each time the flame is ignited.

X2.7 Monitor deposit formation on the burner head and nebulizer. Clean when deposits cause unacceptable absorbance drift.

X2.8 Adjust gas flow rates to minimize carbon deposition on the burner head. Carbon deposition can be particularly troublesome when nebulizing non-aqueous solutions. The burner head can be cleaned with a carbon rod.

X2.9 During analysis, continually observe the appearance of the flame to note any change in conditions.

X2.10 Prevent leakage of acetone from the acetylene cylinders by monitoring cylinder pressure and replacing the cylinder when the pressure is less than 75 psig.

X2.11 Prior to analysis, check the alignment of the hollow cathode lamp.

X2.12 Clean all apparatus to prevent contamination.

X2.13 Establish the frequency of preparation of standards by experiment.

X2.14 Matrix match standard and sample solutions as closely as possible.

X2.15 Prepare and analyze reagent blanks. Correct final results for blank contributions.

X2.16 Establish and implement a QC protocol that can aid in achieving the required data quality.

X2.17 For sample decompositions (Test Method A), follow good laboratory practices.

X2.17.1 Work in a well-ventilated hood and use adequate protection as prescribed in the appropriate safety practices.

X2.17.2 Prevent contamination from the muffle furnace by covering the sample containers.

X2.17.3 Prepare reagent blanks by processing reagents used in the decomposition through the entire procedure.

X2.17.4 Slowly raise the temperature of oils that are known to contain significant quantities of water. The intent is to avoid spraying oil and acid.

ASTM International takes no position respecting the validity of any patent rights asserted in connection with any item mentioned in this standard. Users of this standard are expressly advised that determination of the validity of any such patent rights, and the risk of infringement of such rights, are entirely their own responsibility.

This standard is subject to revision at any time by the responsible technical committee and must be reviewed every five years and if not revised, either reapproved or withdrawn. Your comments are invited either for revision of this standard or for additional standards and should be addressed to ASTM International Headquarters. Your comments will receive careful consideration at a meeting of the responsible technical committee, which you may attend. If you feel that your comments have not received a fair hearing you should make your views known to the ASTM Committee on Standards, at the address shown below.

This standard is copyrighted by ASTM International, 100 Barr Harbor Drive, PO Box C700, West Conshohocken, PA 19428-2959, United States. Individual reprints (single or multiple copies) of this standard may be obtained by contacting ASTM at the above address or at 610-832-9585 (phone), 610-832-9555 (fax), or service@astm.org (e-mail); or through the ASTM website (www.astm.org).