



## Standard Specification for Crates, Wood, Open and Covered<sup>1</sup>

This standard is issued under the fixed designation D 6039/D6039M; the number immediately following the designation indicates the year of original adoption or, in the case of revision, the year of last revision. A number in parentheses indicates the year of last reapproval. A superscript epsilon (ε) indicates an editorial change since the last revision or reapproval.

### 1. Scope

1.1 This specification covers five types and two styles of open and one type, and one style of covered wood crates designed for net loads not exceeding 4000 lb [1814 kg]. Open crates are suitable for shipment of items, which are not readily susceptible to damage from outside forces, and which require only limited protection against the elements.

1.2 If environmental protection is necessary, use of a shroud or a covered crate should be considered. With the exception of Type III, Style B crates, the crates included in this specification are for use in domestic and overseas shipment of net loads not over 4000 lb [1814 kg]. Use shall be confined to items falling within the dimensions and weight limitations of the types and grades specified in Table 1.

1.3 In general, Style A crates have heavier components and are to withstand rather severe handling and multiple shipments (heavy-duty), while Style B crates should be confined to handling and shipping that impose only light to moderate hazards on the container (light-duty). Types I, IV, and V crates are general purpose types; Type II crates are designed for items such as ladders, tubing, extrusions, or wallboard which do not require blocking, bracing, or cushioning; and Type III, Style B crates are designed for such self-supporting material as channels, angles, or other structural members where the container serves only as a means for more convenient stacking and handling.

1.4 The values stated in either inch-pound or SI units shall be regarded separately as standard. The values stated in each system may not be exact equivalents; therefore, each system must be used independently of the other, without combining values in any way.

1.5 *This standard does not purport to address all of the safety concerns, if any, associated with its use. It is the responsibility of the user of this standard to establish appropriate safety and health practices and determine the applicability of regulatory limitations prior to use.*

1.6 If the use of other construction methods or techniques is acceptable and permitted (see 5.1.13), the resulting packaging

systems shall be of equal or better performance than would result from the use of these specified materials and procedures. The appropriate distribution cycle specified in Practice D 4169 can be used to develop comparative procedures and criteria.

### 2. Referenced Documents

#### 2.1 ASTM Standards:

- D 996 Terminology of Packaging and Distribution Environments<sup>2</sup>
- D 1990 Practice for Establishing Allowable Properties for Visually-Graded Dimension Lumber from In-Grade Tests of Full-Size Specimens<sup>3</sup>
- D 3951 Practice for Commercial Packaging<sup>2</sup>
- D 3953 Specification for Strapping, Flat Steel and Seals<sup>2</sup>
- D 4169 Practice for Performance Testing of Shipping Containers and Systems<sup>2</sup>
- D 4675 Guide for Selection and Use of Flat Strapping Materials<sup>2</sup>
- D 6199 Practice for Quality of Wood Members of Containers and Pallets<sup>2</sup>
- F 1667 Specification for Driven Fasteners: Nails, Staples and Spikes<sup>3</sup>

#### 2.2 ASME/ANSI Standards:

- A208.1 Mat-Formed Wood Particleboard<sup>4</sup>
- B18.2.1 Square and Hex Bolts and Screws Inch Series<sup>4</sup>
- B18.5 Round Head Bolts (Inch Series)<sup>4</sup>
- B18.22.1 (B18.22M) Plain Washers<sup>4</sup>

#### 2.3 APA Standard:

- PRP-108 Performance Standards and Policies for Structural-Use Panels<sup>5</sup>

#### 2.4 National Motor Freight Traffic Association Standard: National Motor Freight Classification<sup>6</sup>

#### 2.5 Uniform Classification Committee Standard: Uniform Freight Classification<sup>7</sup>

<sup>2</sup> Annual Book of ASTM Standards, Vol 15.09.

<sup>3</sup> Annual Book of ASTM Standards, Vol 01.08.

<sup>4</sup> Available from the American Society of Mechanical Engineers, United Engineering Center, 345 East 47th St., New York, NY 10017.

<sup>5</sup> Available from the Engineered Wood Assoc., P.O. Box 11700, Tacoma, WA 98411-0700.

<sup>6</sup> Available from the American Trucking Association, Inc., Traffic Department, 2200 Mill Rd., Alexandria, VA 22314.

<sup>7</sup> Available from the Uniform Classification Committee, Tariff Publishing Officer, Room 1106, 222 South Riverside Plaza, Chicago, IL 60606.

<sup>1</sup> This specification is under the jurisdiction of ASTM Committee D10 on Packaging and is the direct responsibility of Subcommittee D10.26 on Shipping Containers, Crates, Pallets, Skids, and Related Structures.

Current edition approved Oct. 10, 2002. Published December 2002. Originally approved in 1996. Last previous edition approved in 1996 as D 6039/D 6039M-96.

**TABLE 1 Crate Classification**

Type	Style A, Heavy Duty				Style B, Light Duty			
	Maximum Net Load (lb/kg)	Inside Dimensions, max			Maximum Net Load (lb/kg)	Inside Dimensions, max		
		Length (ft/mm)	Width (ft/mm)	Height (ft/mm)		Length (ft/mm)	Width (ft/mm)	Height (ft/mm)
I	250 [113]	4 [1200]	3 [900]	3 [900]	200 [90]	4 [1200]	3 [900]	3 [900]
II <sup>A</sup>	1000 [450]	12 [3600]	4 [900]	2 [450]		No Style B		
III		No Style A			No load or size restriction except as limited by handling methods			
IV	1000 [450]	6 [1829]	4 [900]	4 [900]		No Style B		
V <sup>B</sup>	2500 [1125]	12 [3600]	6 [1829]	6 [1829]	4000 [1814]	32 [9600]	6 [1829]	10 [3000]

<sup>A</sup>Items such as ladders, tubing, and extrusions weighing less than 200 lb [90 kg] and not exceeding 20 ft [6000 mm] long, 3 ft [900 mm] wide and 2 ft [600 mm] high may be packed in Type II crates.

<sup>B</sup>Type V, Styles A and B crates shall be further classified as being either nondemountable or demountable. Type V, Style B crates may be open or covered.

### 3. Terminology

3.1 General definitions for packaging and distribution environments are found in Terminology D 996.

### 4. Classification

4.1 Crates covered by this specification shall be of the types and styles shown in Table 1 for maximum net loads and maximum dimensions.

### 5. Ordering Information

5.1 Purchasers should select the preferred options permitted herein, and include the following information in procurement documents:

- 5.1.1 Title, number, and date of this specification,
- 5.1.2 Type and style of crate required (see 4.1),
- 5.1.3 Combination of end and side panels required (see 7.7.2),
- 5.1.4 When interior side battens shall be replaced by exterior side cleats for forklift handling (see 7.7.4),
- 5.1.5 Alternative method of assembly of demountable crate if required (see 7.10.6),
- 5.1.6 When demountability is required for Type V crates (see 7.10 and 7.11),
- 5.1.7 When Type V, Style B crates shall be open or covered (see 7.11),
- 5.1.8 When covering material shall be other than as specified (see 7.11.6),
- 5.1.9 When demountability is required for covered crates (see 7.11.7),
- 5.1.10 When assembly instructions shall be furnished (see 7.12),
- 5.1.11 When the crates are to be furnished other than knocked down (see 9.1),
- 5.1.12 When packaging (see 9.1) and marking (see 9.2) is other than as specified, and
- 5.1.13 When proof that other construction methods or techniques are acceptable (see 1.6) is required.

### 6. Materials

6.1 *Materials*—Materials not specified shall be selected by the contractor/crate builder and shall be subject to all the provisions of this specification. Materials shall be free of defects, which adversely affect performance or serviceability of the finished product.

6.2 *Lumber*—Lumber for all components shall conform to Practice D 6199. Wood members shall be the industries'

commonly accepted practice for nominal sizes and wood groups and shall conform to commercial practice standards in accordance with Practice D 1990, unless otherwise specified.

6.3 *Plywood/Standard Use*—All plywood shall be performance-rated paneling manufactured in accordance with APA PRP-108, or ANSI A208.1.

6.4 *Nails*—Nails shall be steel and shall be coolers, sinkers, corkers, or common in accordance with Specification F 1667.

6.5 *Bolts and Nuts*—Bolts and nuts including lag bolts shall conform to ASME/ANSI B18.2.1 and ASME/ANSI B18.5.

6.6 *Washers*—Washers shall be round carbon steel general-purpose washers and conform to ASME B18.22.1 (B18.22.M).

6.7 *Metal Strapping*—Strapping used to reinforce crates shall conform to Specification D 3953. Strapping finish shall be as specified herein.

### 7. Construction

7.1 *Nails and Nailing*—For fastening covering materials to members, the length of nails shall not be less than 1 in. [25 mm] and shall not exceed the sum of the thickness of the covering material and the member. Nail sizes specified for the fabrication of the various crates are based on Group I and II woods (see Practice D 6199). When Group III and IV woods are used, nail sizes may be one penny size smaller than those specified. The patterns to be used for the nailing of two flat pieces of lumber shall conform to the details shown in Fig. 1 or as specified herein. Unless otherwise specified herein, the following requirements shall determine size, placement, and quantity of nails:

7.1.1 All adjacent crate members shall be fastened to each other, either directly or by means of the covering.

7.1.2 All nails that are not to be clinched shall be cement coated or mechanically deformed (helically or annularly threaded).

7.1.3 Nails shall be driven through the thinner member into the thicker member wherever possible.

7.1.4 When the flat faces of lumber are nailed together and the combined thickness is 3 in. [75 mm] or less (except for the top joists and covering material), nails shall be long enough to pass through both thicknesses and shall be clinched not less than ¼ in. [6 mm] nor more than ⅜ in. [9 mm].

7.1.5 When the flat faces of lumber are nailed together and the combined thickness is more than 3 in. [75 mm] or when the flat face of one or more pieces is nailed to the edge or end face of another, nails shall not be clinched. The portion of the nail

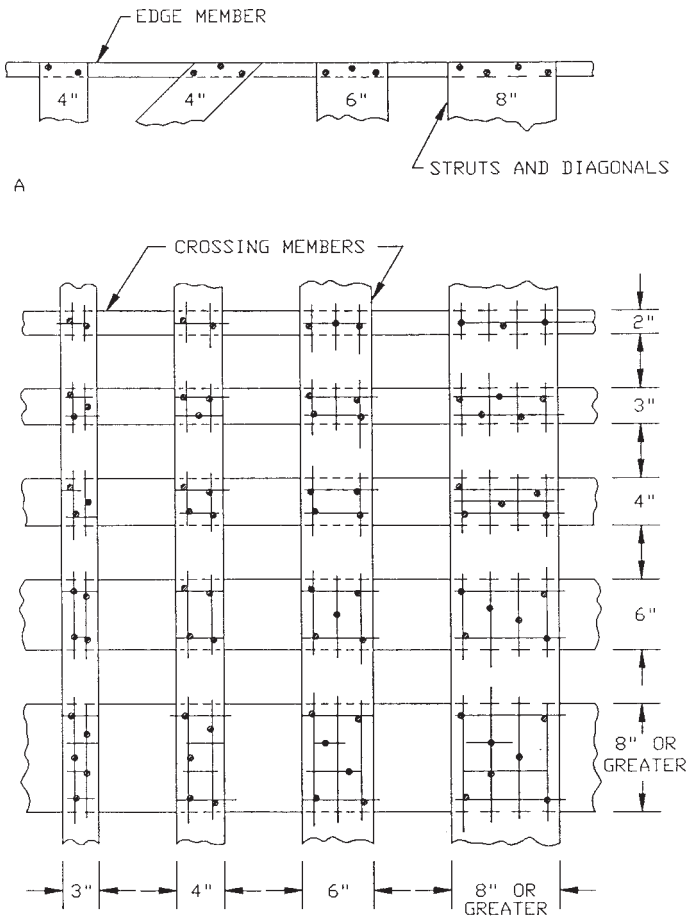

NOTE 1—All widths are nominal.  
 NOTE 2—Similar patterns shall be used when boards cross at angles other 90°.

FIG. 1 Nailing Patterns

in the thicker piece shall not be less than two times the length of the nail in the thinner pieces for ten penny nails and smaller, and not less than 1½ in. [38 mm] for twelve penny nails and larger.

7.1.6 When splitting occurs with the use of diamond-point nails, the nails shall be slightly blunted. When blunting does not prevent the splitting, holes slightly smaller than the diameter of the nail shall be drilled for each nail.

7.1.7 Nails shall be driven so that neither the head nor the point projects above the surface of the wood. Occasional overdriving will be permitted, but nails shall not be overdriven more than one eighth the thickness of the piece holding the head.

7.1.8 Nails shall be positioned not less than the thickness of the piece from the end nor less than one half the thickness of the piece from the side edge of the lumber whenever possible. Nails driven into the side edge of lumber shall be centered on the side edge.

7.1.9 When two members having parallel grain are attached, the number of rows of nails shall be determined by the nominal width of surfaces in contact, one row for widths up to and including 2 in. [50 mm], two rows for widths between 2 in. [50

mm] and 6 in. [150 mm], and three rows for widths over 6 in. [150 mm].

7.1.10 When plywood is nailed to cleats, nails shall be spaced not more than 4 in. [100 mm] apart on centers placed in staggered rows which are not less than 1¾ in. [44 mm] apart or less than ¾ in. [19 mm] from the edge of the cleat.

7.2 Bolt Application—Holes shall be prebored to receive carriage bolts and shall be the exact diameter of the bolt. The lead holes for lag bolts shanks shall be the same diameter as the shank, even though the threaded portion may have a greater diameter than the shank. The diameter of the lead hole for the threaded part of the lag bolt shall be as in Table 2.

7.2.1 Lag bolts shall be placed by being turned in the holes the full length of the bolt and shall not be driven in with a hammer or by any similar means. If for any reason the thread in the wood is stripped when the lag bolts are placed, the lag bolt shall be removed and placed in a new hole near the old position. A flat washer shall be used under the head of each lag bolt and under the nut of each carriage bolt. After the nut is placed, the thread of the carriage bolt projecting beyond the nut shall be painted with a suitable metal primer or similar material.

7.3 Staples—The crown of the staples used for fastening covering materials to frame members shall not be less than ¾ in. [9 mm]. The length of the staples shall not exceed the sum of the thickness of the covering material and the frame member; except that, staples shall never be less than 1 in. [25 mm] in length.

7.4 Splices—Splices and butt joints made in frame members and skids of long crates shall be as shown in Fig. 2.

7.5 Type I Crates—Style A—The load and size limitations shall be as specified in Table 1. Style A crates shall be used only for items forming a Type I load and weighing not more than 250 lb [113 kg].

7.5.1 Base—Skids shall be nominal 2 by 4 lumber. Diagonals shall be 1 by 4 in. [25 by 100 mm] in size. End floor members shall be the same thickness and width as the skid, except that when used as load-bearing members, their sizes shall be as specified in Table 3. End floor members shall be bolted to each skid with ¾-in. [9-mm] diameter carriage bolts as specified in 7.2. Single-piece rubbing strips used on each skid shall be minimum 3 by 4 in. [75 by 100 mm] in size and beveled at each end at an angle of 45° for at least one-half their thickness. The rubbing strip length shall be less than the skid length to allow open space at each end for sling and fork truck handling. The open space shall not be less than 4 in. [100 mm] and not more than 10-in. [250-mm] long. On crates over 36-in. [900-mm] long, the rubbing strip length shall be adjusted to

TABLE 2 Lead Hole Diameter for Threaded Part of Lag Bolt

Diameter of Threaded Portion of Lag Bolt, in. [mm]	Diameter of Lead Hole	
	Group I, II, and III Woods, in. [mm]	Group IV Woods, in. [mm]
¼ [6]	¾ <sub>16</sub> [5]	¾ <sub>16</sub> [5]
¾ <sub>16</sub> [8]	¼ [6]	¼ [6]
¾ [10]	¼ [6]	¾ <sub>16</sub> [8]
½ [13]	¾ [10]	7 <sub>16</sub> [11]
¾ [16]	¾ [10]	½ [13]
¾ [19]	½ [13]	¾ [16]

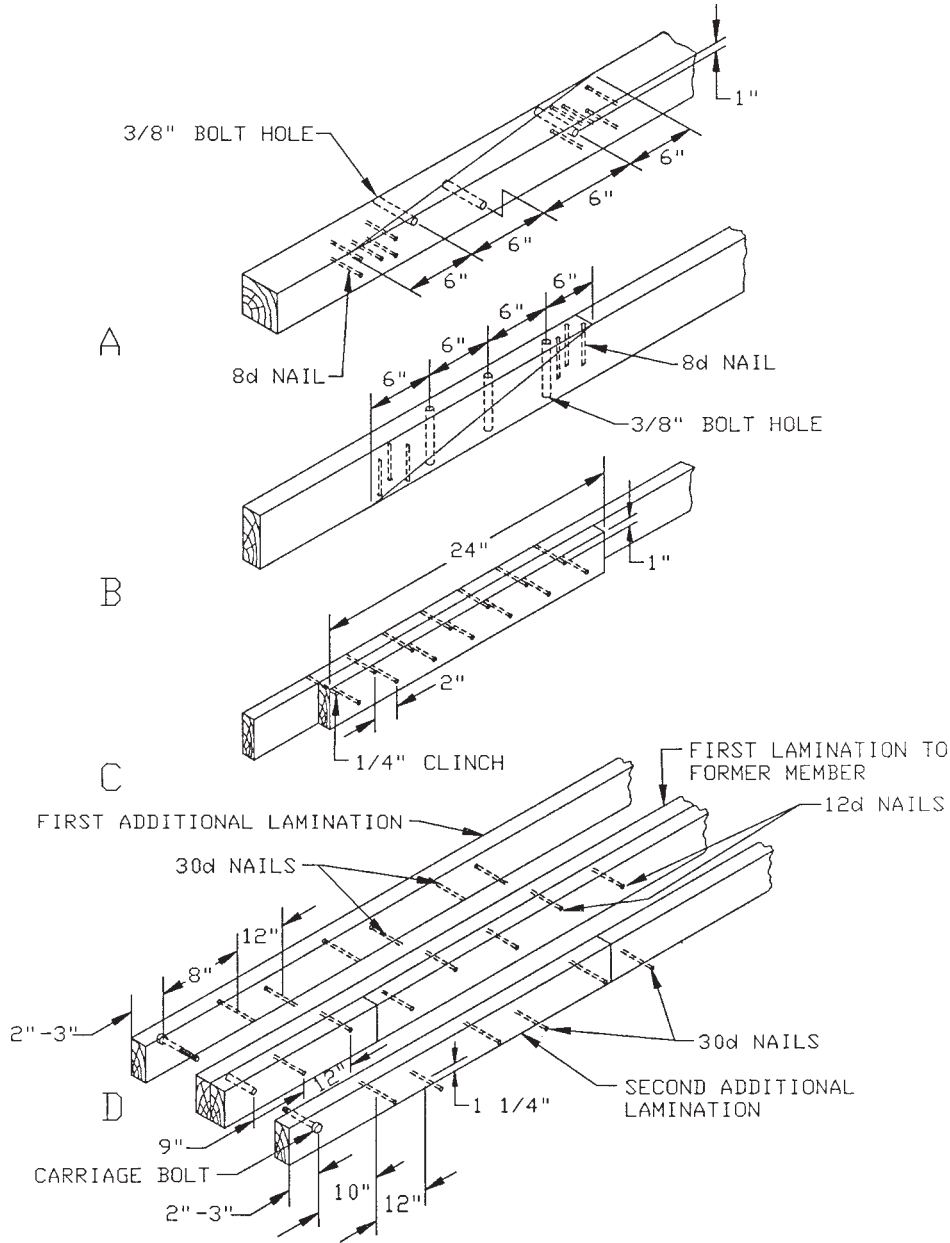

NOTE 1—A—splice of 4-by-4 in. or 4-by-6 in. skids; B—splice of 2-in. member; C—splice of 1-in. member; D—lamination of skid.

FIG. 2 Splicing of Members

TABLE 3 Allowable Load in lb [kg] Per in. [mm] of Load-Bearing Floorboard Width of Groups I and II Woods

NOTE 1—When Group IV woods are used, the allowable loads may be increased by 20 %.

Distance Between Skids, in. [mm]	Nominal Thickness of Floorboard, in. [mm]					
	1 [25]	2 [50]	3 [75]	4 [100]	6 [150]	8 [200]
12 [30]	50 [18]	200 [90]	557 [251]	1090 [491]	2690 [1211]	4680 [2106]
18 [450]	34 [15]	134 [60]	370 [167]	740 [333]	1790 [806]	3140 [1413]
24 [600]	25 [11]	100 [45]	280 [126]	545 [245]	1350 [608]	2330 [1049]
30 [750]	20 [9]	80 [36]	222 [100]	450 [203]	1150 [518]	1870 [842]
36 [900]	17 [8]	66 [30]	185 [83]	361 [162]	895 [403]	1560 [702]
42 [1050]	15 [7]	57 [27]	158 [71]	311 [140]	767 [345]	1335 [601]
48 [1200]	12 [5]	50 [23]	139 [63]	272 [122]	671 [302]	1170 [527]
54 [1350]	11 [5]	45 [20]	124 [55]	242 [110]	596 [268]	1039 [468]
60 [1500]	10 [5]	40 [18]	111 [50]	218 [98]	537 [242]	936 [421]
66 [1650]	9 [4]	37 [17]	104 [47]	198 [89]	488 [220]	850 [383]

provide a distance of not more than 28 in. [700 mm] between end openings.

7.5.2 *Side, End, and Top Panels*—All members of the side, end, and top panels shall be nominal 1 by 4 lumber. Nailing and nailing patterns shall be as specified in 7.1 and as shown in Fig. 1.

7.5.3 *Assembly*—Assembly of crates shall be as shown in Fig. 3 and as specified herein. Nailing shall be as specified herein and in 7.1. The sides shall be fastened to the base by nailing the extensions of the vertical struts and diagonals to the skids with eight penny nails. The ends shall be fastened to the base by nailing the lower edge member of the end panels to the

end floor member with eight penny nails spaced 6 to 8 in. [150 to 200 mm] apart. The sides shall be fastened to the ends by nailing the end vertical struts of the sides to the vertical struts of the ends with eight penny nails spaced 8 to 10 in. [200 to 250 mm] apart. The sides shall be fastened to the top by nailing the extensions of the diagonals and vertical struts of the longitudinal members of the top with eight penny nails. The top shall be fastened to the ends by nailing the extensions of the longitudinal and diagonal members of the top to the upper edge member of the ends with eight penny sinker nails. The upper edge members of the ends shall be nailed to the edge lateral members of the top with eight penny nails spaced 8 to 10 in.

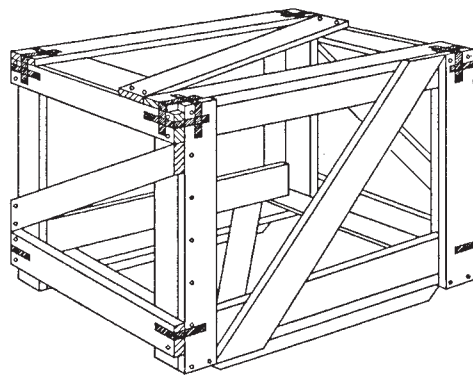
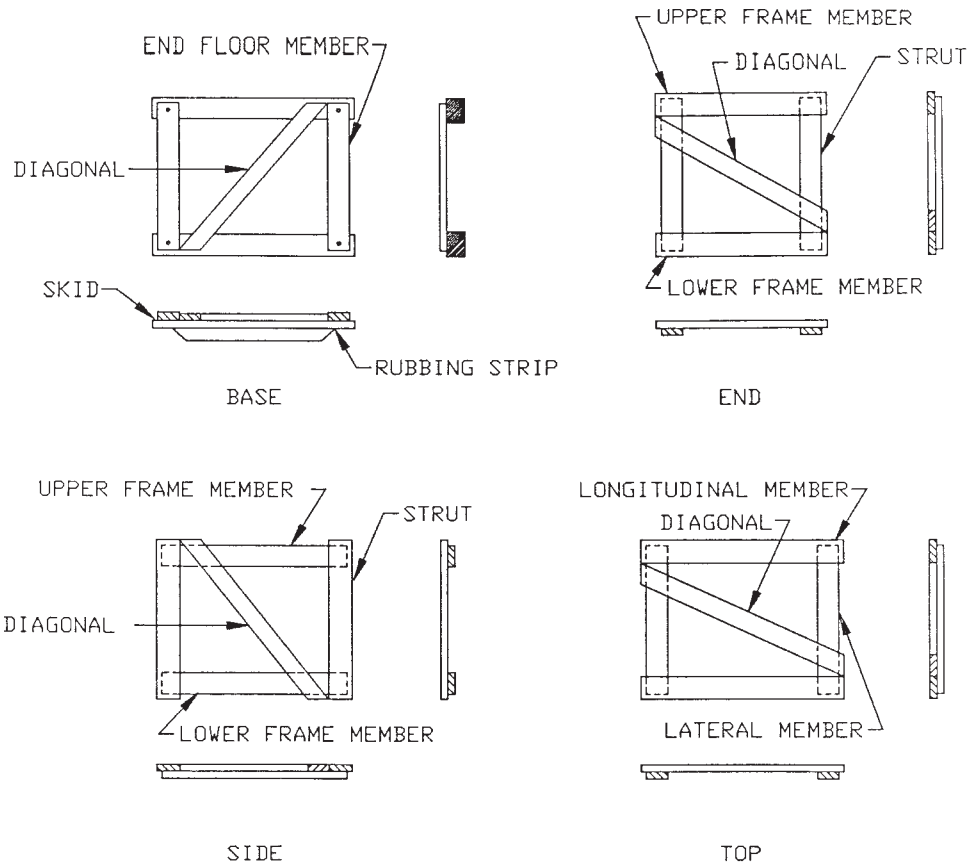

ASSEMBLED

FIG. 3 Type I, Style A Crate Assembly



[200 to 250 mm] apart.

7.6 *Type I Crates—Style B*—The load and size limitations shall be as specified in Table 1. Style B crates shall be used only for items forming a Type I load and weighing not more than 200 lb [90 kg].

7.6.1 *Frame Member Sizes*—All frame members shall be 1 by 3 in. [75 by 100 mm] in size for net loads up to 100 lb [45 kg] and 1 by 4 in. [25 by 100 mm] in size for loads between 100 and 200 lb [45 and 90 kg].

7.6.2 *Assembly*—Assembly of the crates shall be as shown in Fig. 4. Diagonals, struts, crossmembers, and longitudinal members shall be nailed together in patterns as shown in Fig. 1 with six penny nails.

7.7 *Type II Crates—Style A*—The load and size limitations shall be as specified in Table 1.

7.7.1 *Ends*—The ends shall be of lumber or cleated-plywood as shown in Fig. 5. The cleats shall be fastened to the end boards or to the plywood with two rows of nails spaced 4 in. [100 mm] apart in each row, staggered and clinched. The minimum thickness of the end boards and plywood and the minimum size of the end cleats shall be as in Table 4. Additional vertical filler cleats shall be used in the ends when the unsupported span between cleats is greater than 36 in. [900 mm].

7.7.2 *Sides*—The sides of the crates shall be of lumber or cleated-plywood as shown in Fig. 5. When lumber is used, the sides shall be constructed of not more than three pieces for heights of 15 in. [375 mm] or more, not more than two pieces for heights between 7½ and 15 in. [188 and 375 mm], and one piece for heights 7½ in. [188 mm] or less. The minimum thickness of the lumber and plywood, and the minimum size of cleats for plywood sides shall be as in Table 5. When lumber

sides are composed of two or more pieces, battens of the same thickness and width as the top and bottom crossmembers, as specified in 7.6.1, shall be extended the full depth of the sides and shall be fastened to the inside surfaces of the sides as shown in Fig. 5. The battens or cleats of the sides shall be placed to coincide with the crossmembers of the top, and spacing shall not be greater than 36 in. [900 mm]. Battens or cleats shall be fastened to the side boards or plywood with two rows of nails spaced 4 in. [100 mm] apart in each row, staggered, and clinched. When the overall length of the crate exceeds 14 ft [4200 mm], pieces of lumber used in the construction of the sides shall be either the required full length or shall be made of two pieces which together make up the full length. The joint of such pieces shall abut on a full depth batten, and both pieces shall be nailed to the batten. When plywood is used, the sides shall be constructed of one-piece material for width requirements. Butt joints of plywood at an intermediate cleat location will be permitted when two lengths of plywood are required for crates in excess of 96 in. [2400 mm] in length. Crates may have one of the following combinations of sides and end panels, as specified (see 5.1): (1) lumber ends and sides; (2) cleated-plywood ends and sides; and, (3) lumber ends and cleated plywood sides.

7.7.3 *Top and Bottom Members*—The top and bottom members shall be nominal 1 by 4 lumber for all crates up to and including 30 in. [750 mm] in width and nominal 1 by 6 lumber for crates more than 30 in. [750 mm] in width. The angle between the diagonals and sides shall be between 30 and 60°. Crossmembers and supporting side battens or cleats shall be placed not more than 36 in. [900 mm] apart and in line with each other. The crossmembers of the top and bottom shall be directly opposite each other. Bottom diagonals shall be in

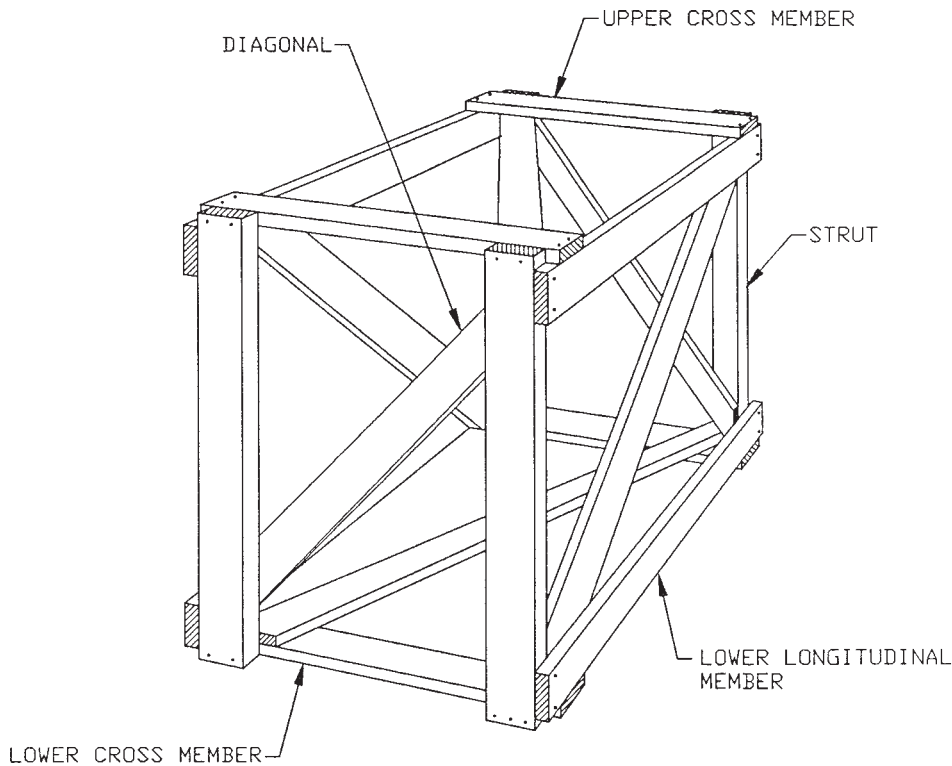

**FIG. 4 Type I, Style B Crate Assembly**

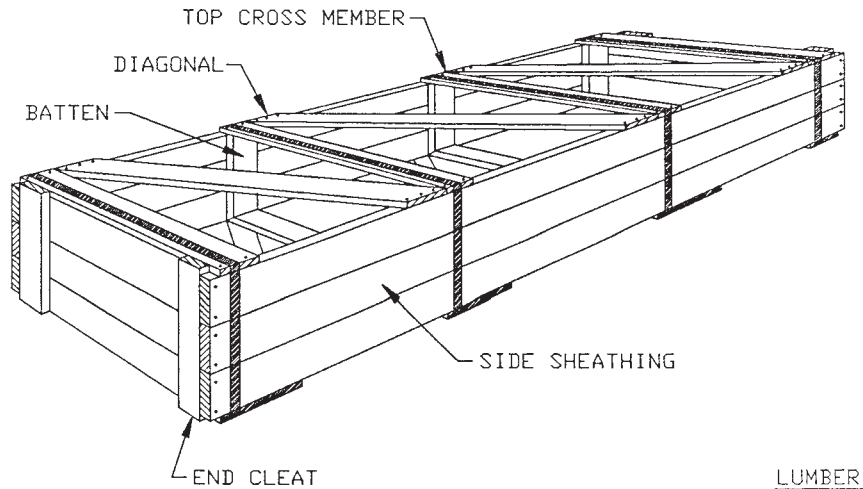

LUMBER

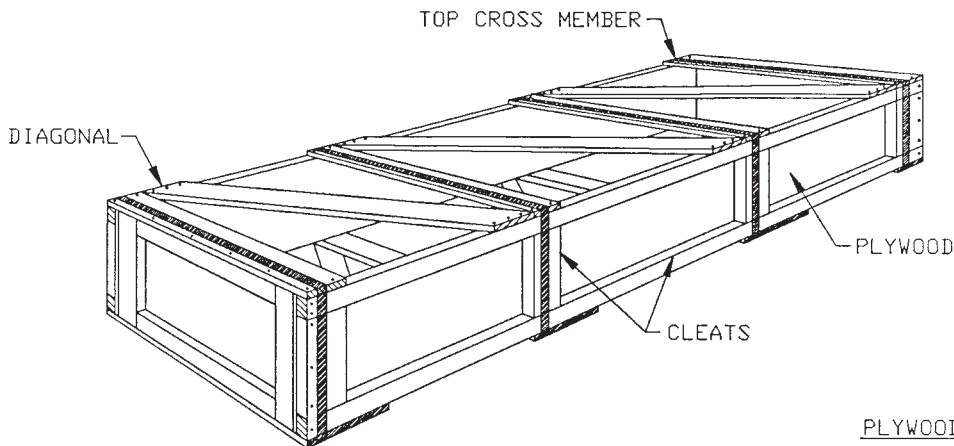

PLYWOOD

FIG. 5 Type II, Style A, Crate Assembly

TABLE 4 Thickness of Ends

Maximum Net Load, lb [kg]	Plywood, in. [mm]	Lumber, in. [mm]	Size of End Cleats, in. [mm]
100 [45]	¼ [6]	¾ [18]	¾ × 2 ¾ [18 × 68]
250 [113]	⅜ [9]	¾ [18]	¾ × 3 ½ [18 × 63]
500 [225]	½ [13]	1 ⅙ [27]	1 ⅙ × 3 ½ [27 × 88]
1000 [450]	½ [13]	1 ⅙ [33]	1 ½ × 3 ½ [38 × 88]

TABLE 5 Thickness of Sides

Maximum Net Load, lb [kg]	Plywood, in. [mm]	Lumber, in. [mm]	Size of Cleats for Plywood Sides, in. [mm]
100 [45]	¼ [6]	¾ [18]	¾ × 2 ¾ [18 × 68]
250 [113]	⅜ [9]	¾ [18]	¾ × 2 ¾ [18 × 68]
500 [225]	½ [13]	1 ⅙ [27]	7/8 × 3 ½ [22 × 88]
1000 [450]	½ [13]	1 ⅙ [33]	7/8 × 3 ½ [22 × 88]

reverse direction with the top diagonals as shown in Fig. 5.

7.7.4 *Exterior Side Cleats*—When specified (see 5.1), for gross weights exceeding 200 lb [90 kg], exterior side cleats shall be used to facilitate fork truck handling of crates. On lumber sides, the exterior cleats shall replace the interior side battens. On plywood sides, filler pieces shall be used under the

exterior side cleats; filler pieces shall pass between the horizontal cleats and shall be the same width as the exterior cleats. Spacing of cleats shall be as shown in Fig. 6. Size of exterior side cleats shall be 3 by 4 in. [75 by 100 mm]. Exterior side cleats shall be secured to the side sheathing with nails as specified for battens in 7.7.2. Short one-panel crates with lumber ends shall have end cleats a nominal 3 in. [75 mm] thick in lieu of exterior cleats.

7.7.5 *Assembly:*

7.7.5.1 *Sides to Ends*—The sides shall be nailed with sinker or corker nails to the ends as specified in Table 6. Nailing shall be as specified in 7.4.1.

7.7.5.2 *Top and Bottom Member to Sides*—The top and bottom crossmembers and diagonals shall be nailed to the cleats of the sides or to the lumber sides with eight penny sinker nails when the side cleats or sides are less than 1 in. [25 mm] in thickness and nine penny sinker nails when side members are 1 in. [25 mm] or more in thickness. The end, top, and bottom crossmembers shall be nailed to the end sheathing or cleats, if the ends are lumber or plywood, respectively. The nailing patterns, location of nails, and nailing procedures shall be as shown in Fig. 1 and as specified in 7.1.

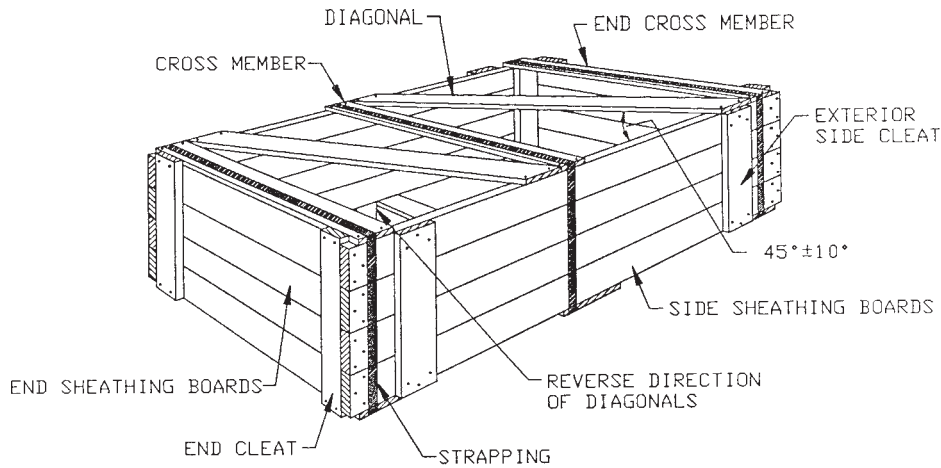

A

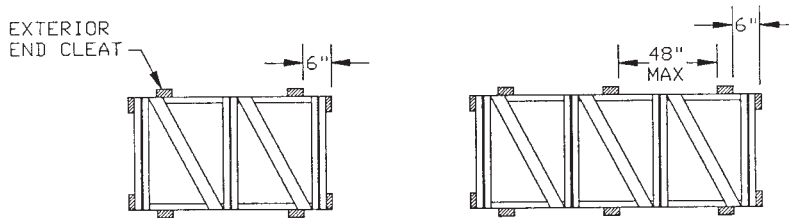

B

C

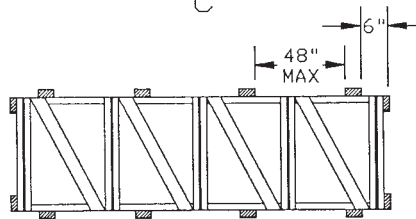

D

NOTE 1—A—complete crate; B—two panel; C—three panel, and D—four panel.

FIG. 6 Type II, Crate with Exterior Side Cleats

TABLE 6 Nailing Schedule for Assembly of Type II, Style A Crates

Plywood Thickness, in. [mm]	Cleated-Plywood Sides to Plywood or Lumber Ends <sup>A</sup>		Lumber Sides to Lumber Ends <sup>A</sup>		
	Nail Size, penny	Spacing, in. [mm]	Thickness of Sides, in. [mm]	Nail Size, penny	Spacing, in. [mm]
¼ [6]	8	3 [75]	¾ [18]	8	2½ [63]
⅜ [9]	10	3¼[81]	1¼[27]	10	2¾[68]
½ [13]	12	3½[88]	1½[33]	12	3 [75]

<sup>A</sup>Nails shall be staggered when ends are lumber.

7.8 Type III Crates—Style B—Style B crates shall be as shown in Fig. 7. There shall be no size or load restrictions for this crate except as limited by handling methods (see 6.1). The size and spacing of members shall be as specified in Table 4. Vertical end cleats shall be long enough to permit full nailing to the upper horizontal end cleats when the crate is assembled.

7.8.1 Nailing—The upper and lower halves of the crate shall be fabricated with six penny nails; the vertical end cleats shall be fastened to the lower horizontal end cleats with clinched nails. Two nails shall be used in each end of 3- and

4-in. [75- and 100-mm] wide longitudinal members and three nails shall be used in 6-in. [150-mm] wide longitudinal members.

7.8.2 Rubbing Strips—Beveled rubbing strips, of sizes shown in Table 7, shall be attached to the undersurface of each lower crossmember to facilitate fork lift handling. Rubbing strips shall be fastened to the crossmembers with sixteen penny nails placed in two rows, spaced 5 in. [125 mm] apart in each row, and clinched. Rubbing strips shall be applied at time of crate packing after strapping has been secured to crossmembers.

7.8.3 Assembly—Assembly of the crates shall be as shown in Fig. 7. After items have been nested in the lower half of the crate, the upper half shall be positioned and strapped in accordance with Guide D 4675. The upper ends of the vertical end cleats shall be nailed to the upper horizontal end cleats with four penny nails. The upper longitudinal members of the sides shall be nailed to the vertical end cleats with eight penny nails.

7.9 Type IV Crates—Style A (see Fig. 8)—The load and size



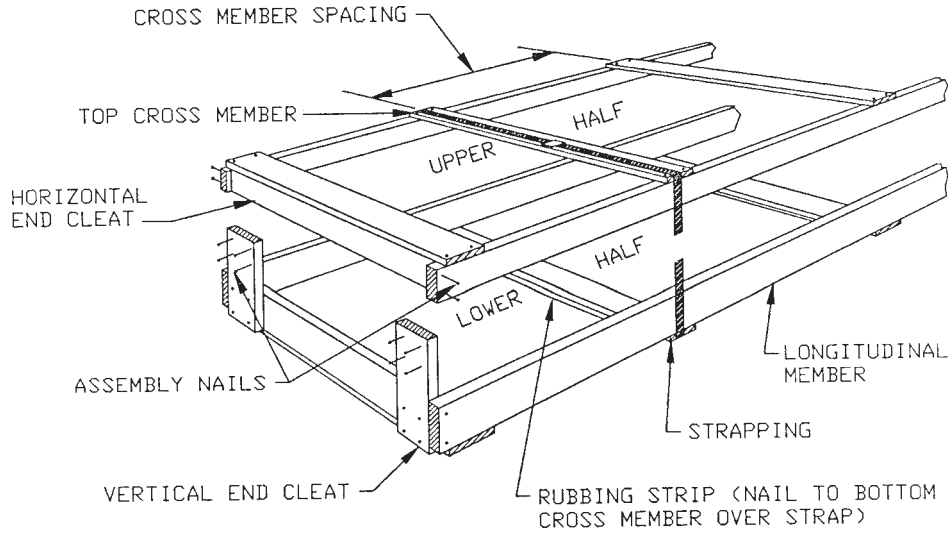

**FIG. 7 Type III, Style B Crate Assembly**

**TABLE 7 Member Sizes and Spacing for Type III, Style B Crates**

Member	Member Size			Member Spacing				
	Depth of Crate, in. [mm]			Width of Crate, in. [mm]		Length of Crate, in. [mm]		
	0 to 8 [0 to 200]	8 to 12 [200 to 300]	Over 12 [Over 300]	0 to 24 [0 to 600]	Over 24 [Over 600]	0 to 120 [0 to 3000]	Over 120 to 240 [Over 3000 to 6000]	Over 240 [Over 6000]
	Nominal Sizes			in. [mm]		in. [mm]		
Longitudinal members	1 × 3	1 × 4	1 × 6	1 × 4	1 × 6	2	2½	3
Vertical end cleats	1 × 3	1 × 4	1 × 6	[25 × 100]	[25 × 150]	50	63	75
Horizontal end cleats	1 × 3	1 × 4	1 × 6	3 × 4	3 × 6			
Top and bottom crossmembers				[75 × 100]	[75 × 150]			
Rubbing strips								

limitations shall be as specified in Table 1.

7.9.1 *Base*—Skids shall be nominal 2 by 4 lumber for loads through 500 lb [225 kg] and nominal 2 by 6 lumber for loads over 500 lb [225 kg]. The size of load-bearing floor members shall be as specified in Table 2. Floorboards over 2 in. [50 mm] in nominal thickness shall be bolted to the skids with 3/8-in. [9-mm] diameter carriage bolts as specified in 7.2. Diagonals shall be nominal 1 by 6 lumber. The size and placement of end floor members and rubbing strips shall be as specified in 7.5.1. On crates over 60 in. [1500 mm] long, the rubbing strips shall be in three pieces, with the center piece 16 in. [400 mm] long, the fork openings 12 in. [300 mm] long, and the end pieces of a length which will allow end sling openings of 4 in. [100 mm].

7.9.2 *Side, End, and Top Panels*—All members of the side, end, and top panels shall be nominal 1 by 6 lumber. Three vertical struts shall be used in the side panels when the length of the crate is greater than 48 in. [1200 mm] or greater than 1½ times the height. The lateral members of the top panel shall coincide with the vertical struts of the side panels and shall be equal in number. Nailing and nailing patterns shall be as specified in 7.1 and as shown in Fig. 1.

7.9.3 *Crate Assembly*—Assembly of the crates shall be as specified in 7.5.1.3 and as shown in Fig. 8. The longitudinal members of the top shall bear upon the struts of the ends and against the inside of the upper frame members.

7.10 *Type V Crates—Style A*—The load and size limitations shall be as specified in Table 1. Nailing shall be as specified in

7.1, as shown in Fig. 1, and as specified herein. Crates shall be assembled with nails or shall be demountable, as specified (see 5.1).

7.10.1 *Base:*

7.10.1.1 *Skids*—The skids shall consist of nominal 4 by 4 lumber. An intermediate 4 by 4 skid shall be used when the distance between the outer skids is greater than 36 in. [900 mm].

7.10.1.2 *Load-Bearing Floor Members*—The size of the load-bearing floor members shall be as specified in Table 3. Floor boards over 2 in. [50 mm] in nominal thickness shall be bolted to each outside skid with 3/8-in. [9-mm] carriage bolts as specified in 7.4.3.

7.10.1.3 *Diagonals*—The diagonals shall be nominal 1 by 6 lumber and the angle between the skid and the diagonal shall be between 30 and 60°, except that when the angle of a single diagonal is less than 30°, two diagonals and a nominal 1 by 6 center crossmember shall be used.

7.10.1.4 *Crossmembers*—End crossmembers shall be nominal 2 by 6 lumber for crates not greater than 48 in. [1200 mm] in width and nominal 4 by 4 lumber for crates over 48 in. [1200 mm] in width. End crossmembers shall be bolted to each skid with 3/8-in. [10-mm] diameter carriage bolts as specified in 7.2.

7.10.1.5 *Rubbing Strips*—Rubbing strips shall be as specified in 7.5.1 and 7.8.2.

7.10.2 *Ends*—Vertical struts shall be nominal 2 by 4 lumber. An intermediate strut shall be used when the width of the crate

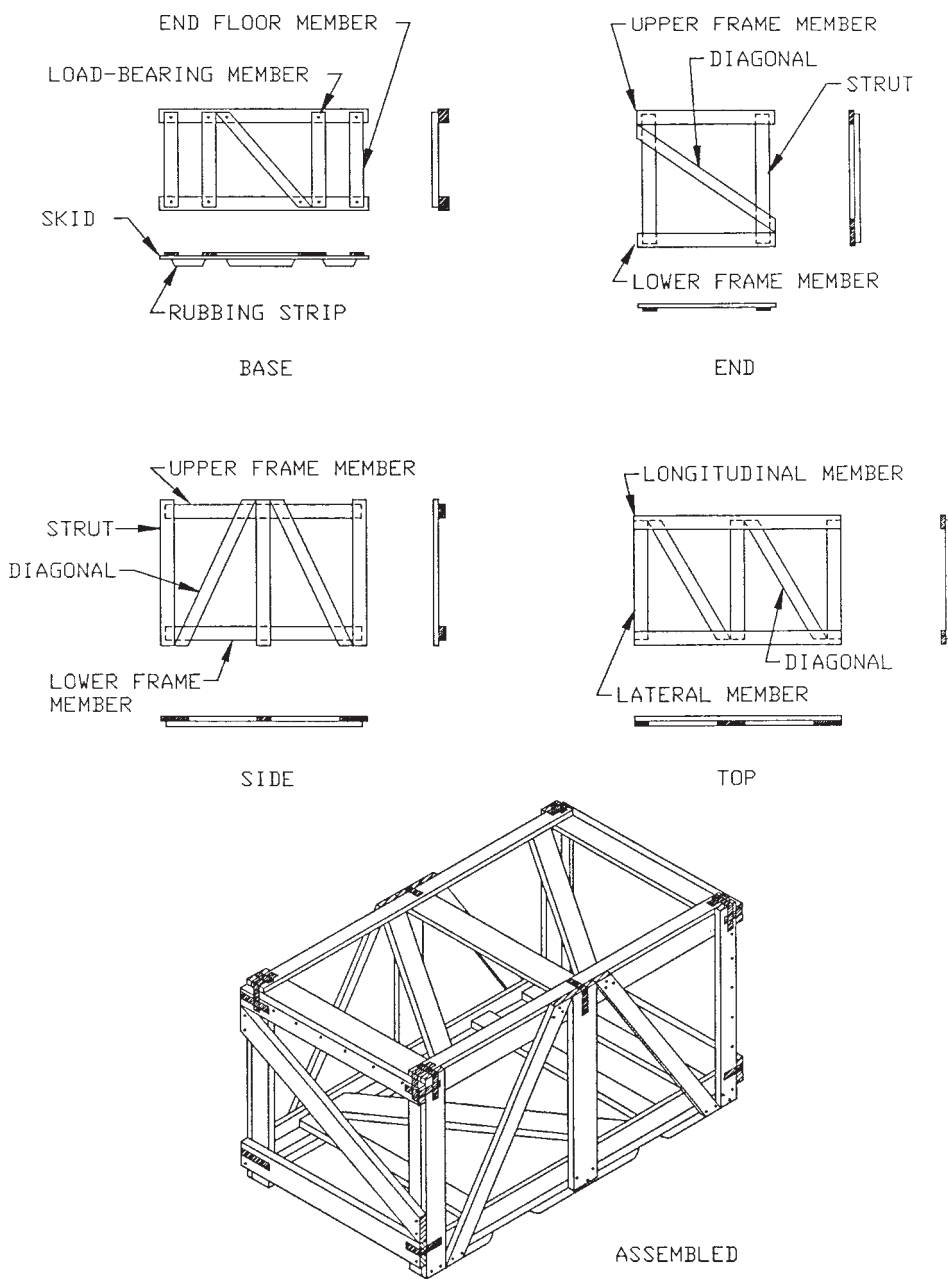

FIG. 8 Type IV, Style A Crate Assembly

is greater than 36 in. [900 mm]. All struts shall coincide with the skids and shall bear upon the end crossmembers of the base. The upper and lower frame members of the ends shall be nominal 1 by 6 lumber except that a nominal 1 by 8 lower member shall be used when the end crossmembers of the base are of nominal 4 by 4 s. The diagonals of the ends shall be nominal 1 by 6 lumber.

7.10.3 *Sides*—All side framing members, struts, and diagonals shall be nominal 1 by 6 lumber. Intermediate struts shall be placed so that diagonals form an angle of between 30 and 60° with the lower frame member. Struts shall have a maximum spacing of 42 in. [1050 mm]. A horizontal intermediate frame member is required when the height of the side exceeds

48 in. [1200 mm]. Diagonals shall be used between each two adjacent struts.

7.10.4 *Top*—All members of the top shall be nominal 2 by 4 lumber. The longitudinal members shall coincide with the vertical struts of the ends. An intermediate longitudinal member is required when the width of the crate is greater than 36 in. [900 mm] and shall coincide with the intermediate struts of the ends. The joists shall be placed flat. Joists shall coincide with each strut of the side but shall be spaced not more than 40 in. [1000 mm] apart for crates up to 36 in. [900 mm] wide and not more than 30 in. [750 mm] apart for crates more than 36 in. [900 mm] wide. The diagonals shall be nailed to the longitudinal members. When more than three joists are used, only

each end panel of the top assembly shall be braced as shown in Fig. 9.

7.10.5 *Nondemountable Crate Assembly*—The assembly shall be reinforced by the application of metal straps as shown in Fig. 9.

7.10.5.1 *Sides to Base*—The sides shall be fastened to the base by nailing the overlap of the vertical struts and diagonals to the skids with twelve penny sinker nails. The nailing patterns shall follow those shown in Fig. 1.

7.10.5.2 *End to Base*—The ends shall be fastened to the base by nailing the lower frame member of the end panels to the end crossmember of the base with twelve penny sinker nails spaced 6 to 8 in. [150 to 200 mm] apart.

7.10.5.3 *Sides to Ends and Ends to Sides*—The edge struts of the sides shall be fastened to the edge struts of the ends with eight penny sinker nails spaced 8 to 10 in. [250 mm] apart. The extensions of the upper and lower frame members and the diagonals of the end shall be nailed to the edge struts of the side with eight penny sinker nails as shown in Fig. 1.

7.10.5.4 *Top to Sides and Ends*—The top shall be fastened to the sides and ends by nailing the upper frame members of the ends and the extensions of the vertical struts and diagonals of the sides to the adjacent edge members of the top with eight penny sinker nails as shown in Fig. 1.

7.10.6 *Demountable and Partically Demountable Crate Assembly*—All demountable crates shall be assembled with lag

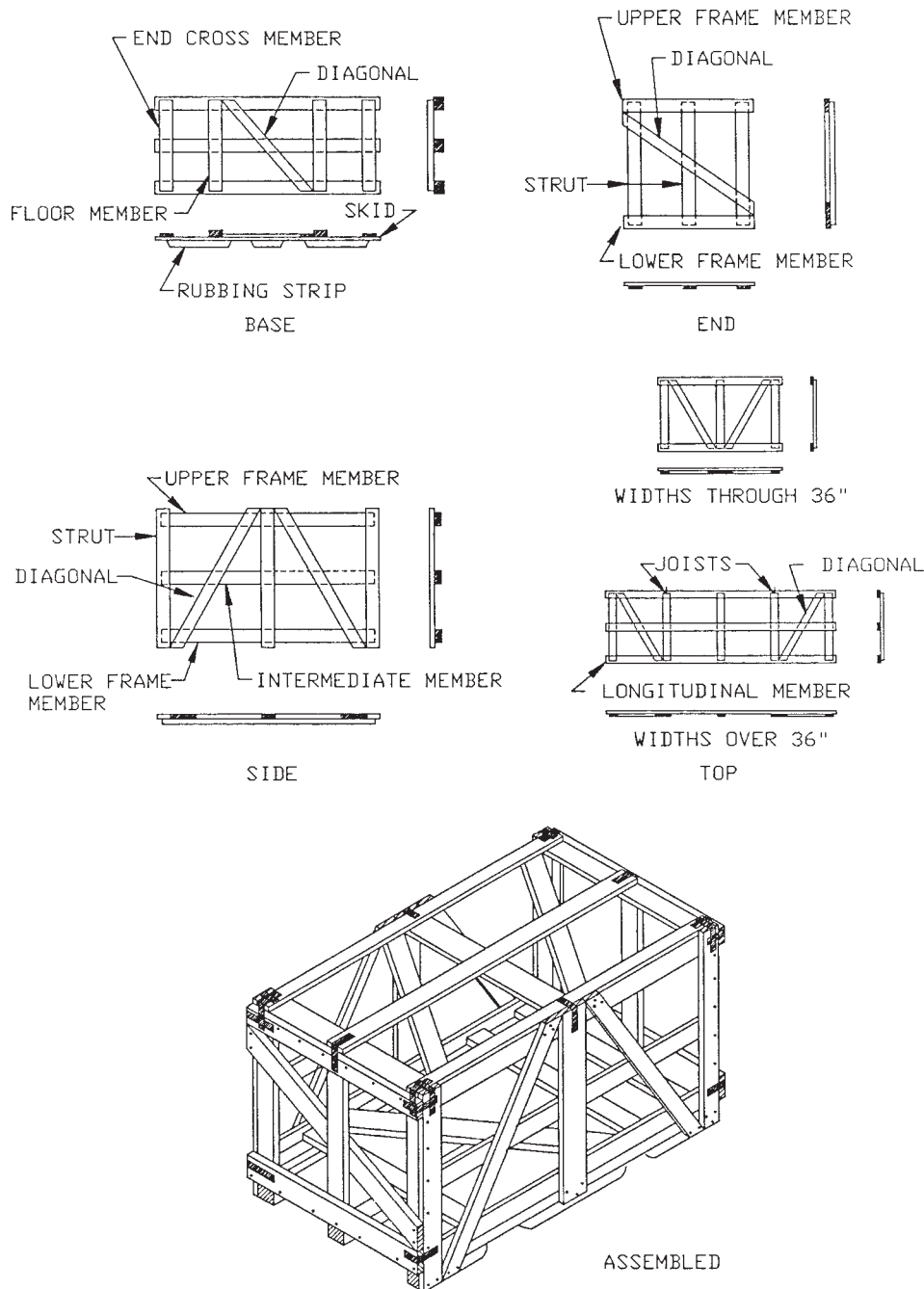

FIG. 9 Type V, Style A Crate Assembly

bolts. Lead holes shall be used for all lag bolts as specified in 7.2. When specified (see 5.1), as an alternate, the top, side, and end panels may be nailed to each other as specified in 7.10.5.3 and 7.10.5.4 and the units may be fastened to the skids and end crossmembers of the base by means of lag bolts for demountable crates as specified in 7.10.6.1 and 7.10.6.2.

7.10.6.1 *Sides to Base*—Lag bolts,  $\frac{3}{8}$  by  $3\frac{1}{2}$  in. [10 by 88 mm], shall be used to fasten the sides to the skids. Diagonals shall be arranged to provide the maximum number of fastening points to the base near the center of the skids. The minimum number of lag bolts shall correspond to the following tabulation. Not less than one lag bolt shall be placed in each strut and diagonal.

Gross Load (Crates and Contents) (lb/kg)	Minimum Number of $\frac{3}{8}$ in. [9 mm] Lag Bolts for Each Side of Crate
1000/450	4
2000/900	5
3000/1350	8

7.10.6.2 *Ends to Base, Sides to Ends, and Ends to Top*—Lag bolts,  $\frac{5}{16}$  by 3 in. [8 by 75 mm], spaced 12 to 14 in. [300 to 350 mm] apart, shall be used to fasten: (1) the lower edge members of the ends to the end cross-members of the base; (2) the end vertical struts of the sides to the edge struts of the ends; and, (3) the upper edge members of the end to the edge joists of the top.

7.10.6.3 *Sides to Top*—One  $\frac{5}{16}$  by 3 in. [8 by 75 mm] lag bolt shall be used to fasten each strut and diagonal of the sides to the edge longitudinal members of the top.

7.11 *Type V Crates—Style B*—The load and size limitations shall be as specified in Table 1. Nailing shall be as specified in 7.1, as shown on Fig. 1 and as specified herein. Type V, Style B crates shall be as shown in Figs. 10-18 and as specified herein. They shall be open or covered, and demountable or non-demountable, as specified (see 5.1).

#### 7.11.1 *Base:*

7.11.1.1 *Skids*—Skid sizes shall conform to the tabulation in Table 8. Crates over 42 in. [1050 mm] wide shall have three skids per side. Splices shall be located no further from the ends than one-third of the length of the skids, and splice locations shall be alternated in adjacent skids. All 4 by 4 members may also consist of two 2 by 4s placed on edge and laminated in accordance with Fig. 2.

7.11.1.2 *Rubbing Strips*—Rubbing strips shall be a minimum of 3 by 4 in. [75 by 100 mm] in size. The strips shall be as specified in 7.5.1 and positioned as shown in Fig. 10. They shall be nailed to the skids with two rows of nails spaced 12 in. [300 mm] apart in each row in a staggered pattern; nail sizes shall be sixteenpenny for 2 by 4 in. [50 by 100 mm] skids, and twenty penny for 3 by 4 in. [75 by 100 mm] and 4 by 4 in. [100 by 100 mm] skids.

7.11.1.3 *End Headers*—Two headers spaced 24 in. [600 mm] apart shall be bolted to each end of the skids as shown in Fig. 10 with  $\frac{3}{8}$ -in. [10-mm] diameter carriage bolts. The end headers shall be the same cross section as the skids. When the crate ends have nominal 2 by 4 struts, bolts in the outer headers shall be placed to clear the struts.

7.11.1.4 *Load-Bearing Floorboards*—When concentrated

loads occur, load-bearing floorboards shall be used to transfer the load to the skids. The sizes shall be as specified as in Table 2. When end headers are used as load-bearing members, the end header size shall be chosen from the load-bearing floorboard width specified in Table 3. Floorboards 2 in. [50 mm] or less in thickness shall be nailed to each skid using nailing patterns as shown in Fig. 1, and floorboards over 2 in. [50 mm] thick shall be bolted to each skid, with  $\frac{3}{8}$ -in. [9-mm] diameter carriage bolts. Two bolts shall be used for floorboards over 6 in. [150 mm] wide.

7.11.1.5 *Diagonals and Floorboards*—Diagonals shall be used between headers and load-bearing floorboards or other crossmembers and shall be placed at an angle as close to  $45^\circ$  as possible. Diagonals and floorboards, other than load-bearing floorboards shall be nominal 1 by 4 members for net loads up to 500 lb and outside widths not exceeding 36 in. [900 mm], and shall be nominal 1 by 6 members for all other conditions.

7.11.2 *Sides*—Sides shall be as shown in Fig. 11, Fig. 12, and Fig. 13. Single-panel sides shall be used for heights not exceeding 72 in. [1829 mm]. An intermediate longitudinal member shall be added for heights over 48 in. [1200 mm]. Double-panel sides shall be used for heights over 72 in. [1829 mm] but not exceeding 96 in. [2400 mm]. Triple-panel sides shall be used for heights over 96 in. [2400 mm]. Longitudinal members shall be in single pieces for lengths not exceeding 192 in. [4800 mm], and may be spliced as shown in Fig. 2 for lengths greater than 192 in. [4800 mm]. Splice locations shall be alternated. Member sizes and spacing shall be as specified in Table 9.

7.11.3 *Ends*—Ends shall be as shown in Fig. 14 and Fig. 15. All members shall be nominal 1 by 4 lumber for net loads up to 500 lb [225 kg], and nominal 1 by 6 lumber for net loads over 500 lb [225 kg], with the following exceptions:

7.11.3.1 Struts shall be nominal 2 by 4 lumber when crate height is over 60 in. [1500 mm].

7.11.3.2 The lower frame member shall be nominal 1 by 6 lumber when the end headers of the base are 2-in. [50-mm] thick members and nominal 1 by 8 lumber when larger end headers are used.

7.11.4 *Top*—The top shall be as shown in Fig. 16. The spacing of the crossmembers shall be the same as the spacing of the side struts. Diagonals shall be nailed to the inner faces of the crossmembers. The longitudinal members shall be nominal 1 by 4 lumber for loads up to 500 lb [225 kg] and widths to 48 in. [1200 mm], and nominal 1 by 6 lumber for all other conditions. Crossmembers and diagonals shall be nominal 1 by 4 lumber for loads to 1000 lb [450 kg] and widths to 48 in. [1200 mm], and nominal 1 by 6 lumber for all other conditions. Splicing of longitudinal members shall be as shown in Fig. 2 and as specified in 7.11.2.

7.11.4.1 *Top Reinforcing Joists*—When the gross weight of the crate is over 500 lb [225 kg], or the inside width is over 42 in. [1050 mm], a nominal 2 by 4 top-reinforcing joist shall be nailed to the top at the center of balance, as shown in Fig. 16, to prevent the top of the crate from being crushed when the crate is lifted with a single set of grabhooks. The joist shall be

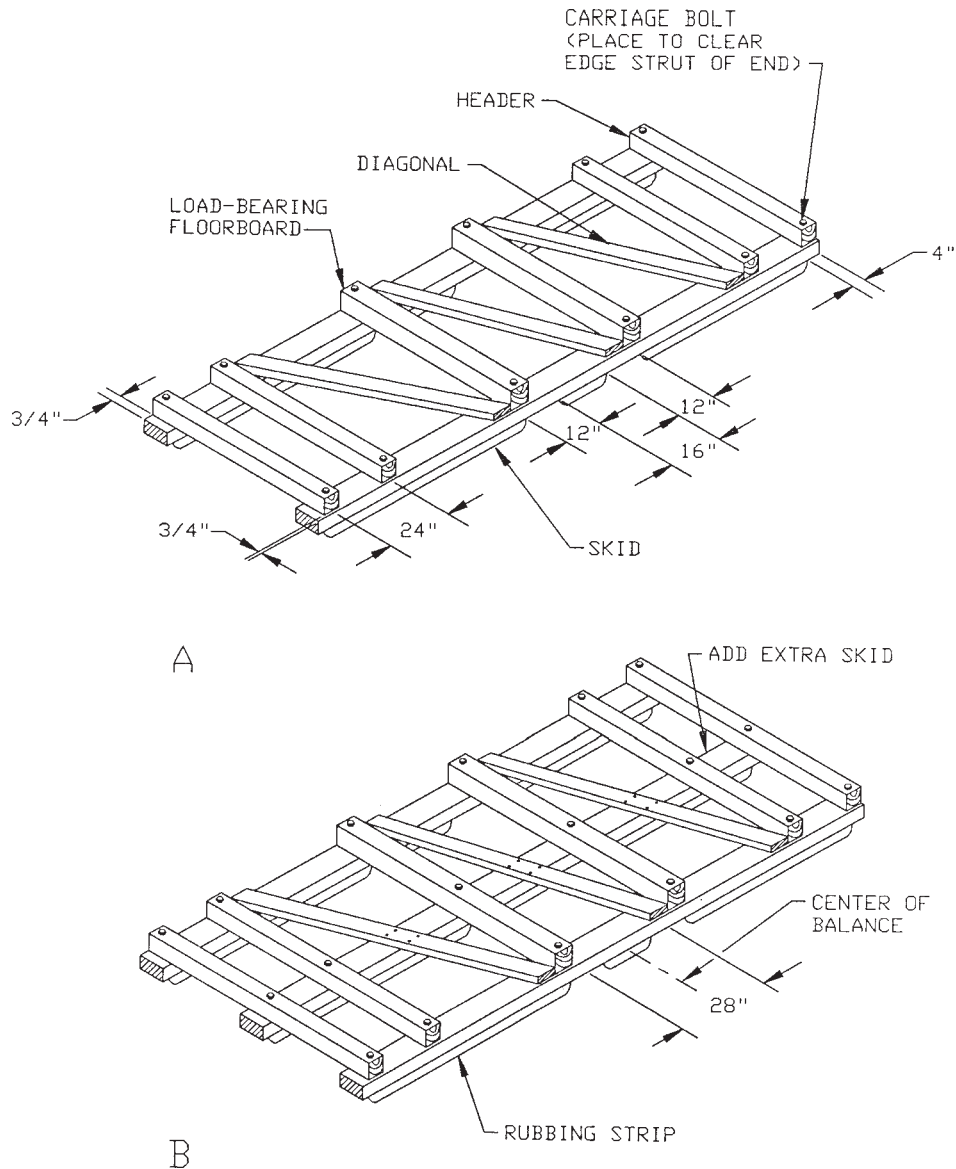

NOTE 1—A—up through 42 in. wide; B—over 42 in. wide.  
**FIG. 10 Bases for Type V, Style B Crates**

placed flat and the ends shall contact the inner face of the upper longitudinal members of the side when the crate is assembled. The joist shall be fastened to the longitudinal and diagonal members of the top with sevenpenny nails placed as shown in Fig. 1 and to the upper longitudinal members of the sides with two ten penny nails in each end.

7.11.5 *Assembly*—Unless demountability is specified, the crate shall be assembled by nailing. When demountability is specified, the sides, ends, and top, as a unit, shall be secured to the base with lag bolts. Eight penny nails, spaced 8 to 10 in. [200 to 250 mm] apart, shall be used to fasten: (1) the edge struts of the sides to the edge struts of the ends; (2) the longitudinal members of the top to the upper frame members of the sides; (3) the end crossmembers of the top to the upper frame members of the ends; and (4) the lower frame members of the ends to the end headers of the base. Eight penny nails as shown in Fig. 1 nailing patterns shall be used to fasten: (1) the

upper ends of the side struts and diagonals to the longitudinal members of the top; and (2) the ends of upper and lower frame members, horizontal members, and diagonals of the ends to the edge struts of the sides. The bottom ends of struts and diagonals of the sides shall be secured to the skids with eight penny nails as follows: A minimum of three nails shall be used for each 3 and 4-in. [75 and 100-mm] wide member, four nails for each 6-in. [150-mm] wide member, and five nails for each 8 in. [200 mm] and wider member. Nails shall be staggered and shall be placed in two rows whenever possible. For demountable crates, each strut and diagonal of the sides shall be fastened to the skids with a minimum of one lag bolt. The size of the lag bolts and the total number required shall not be less than that specified in Table 10. When more than one lag bolt is required in each strut or diagonal, the additional lag bolts shall be placed in the wider members, near the load-bearing points, and in a staggered pattern when possible. One-half the total



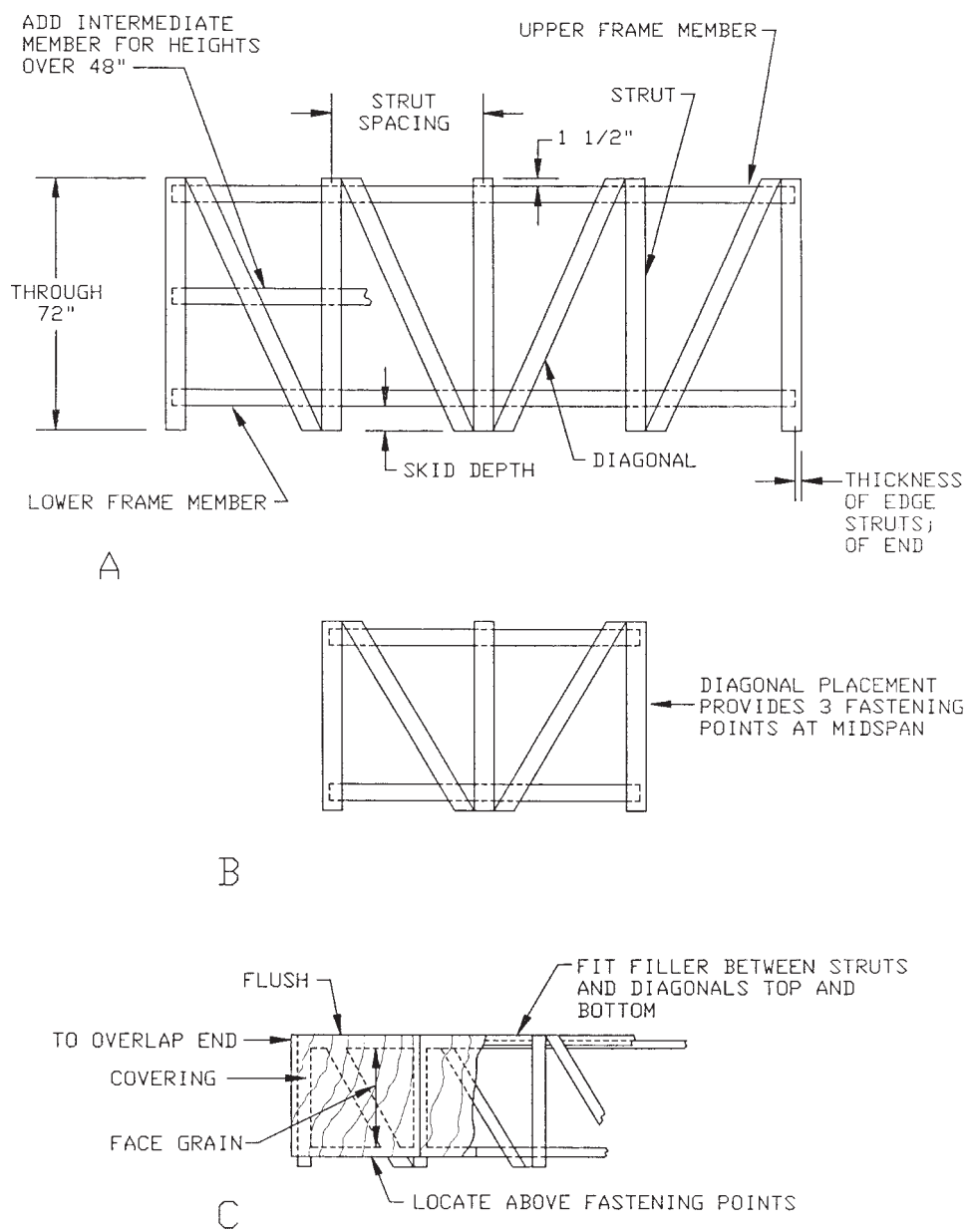

NOTE 1—A—side of long crate; B—side of short crate; C—covered side.  
**FIG. 11 Single-Panel Sides for Type V, Style B Crates**

number of lag bolts required shall be used for each side. For demountable crates, the lower frame members of the ends shall be fastened to the end headers of the base with 5/16 by 3 in. [8 by 75 mm] lag bolts, spaced 12 in. [300 mm] apart.

7.11.6 *Covered Crates*—The structural framework of the covered crates shall be as specified in 7.9.2. The covered crates shall also be as shown in Figs. 11-18. Unless otherwise specified (see 5.1), the covering shall consist of plywood or paper-overlaid veneer, with a minimum thickness of 1/8 in. [3 mm]. When joints are required in the covering, they shall butt over the centerline of struts or crossmembers. Covering shall be fastened with two rows of nails or staples, spaced 8 in. [200 mm] apart in each row, staggered, and unclinched. Filler pieces between struts, diagonals, and crossmembers of sides, ends, and top shall be fastened with two rows of nails, spaced 10 in.

[250 mm] apart in each row, staggered, and clinched. Filler pieces shall be the same thickness as adjacent panel framing members.

7.11.6.1 *Sides*—Filler pieces 4-in. [100-mm] wide shall be fastened to the upper and lower frame members between the struts and diagonals. Fillers shall extend beyond the edge of the upper frame member so as to be flush with the ends of the struts and diagonals. The lower edges of the fillers shall be flush with the bottom edge of the lower frame members.

7.11.6.2 *Ends*—Filler pieces 3-in. [75-mm] wide shall be nailed to the edge struts as shown in Fig. 14 and Fig. 15.

7.11.6.3 *Tops*—Filler pieces 2-in. [50-mm] wide shall be fastened to the longitudinal members. The covering of the top shall be extended to overlap the covering of the sides and ends. During nailing, a 4-in. [200-mm] wide strip of waterproof

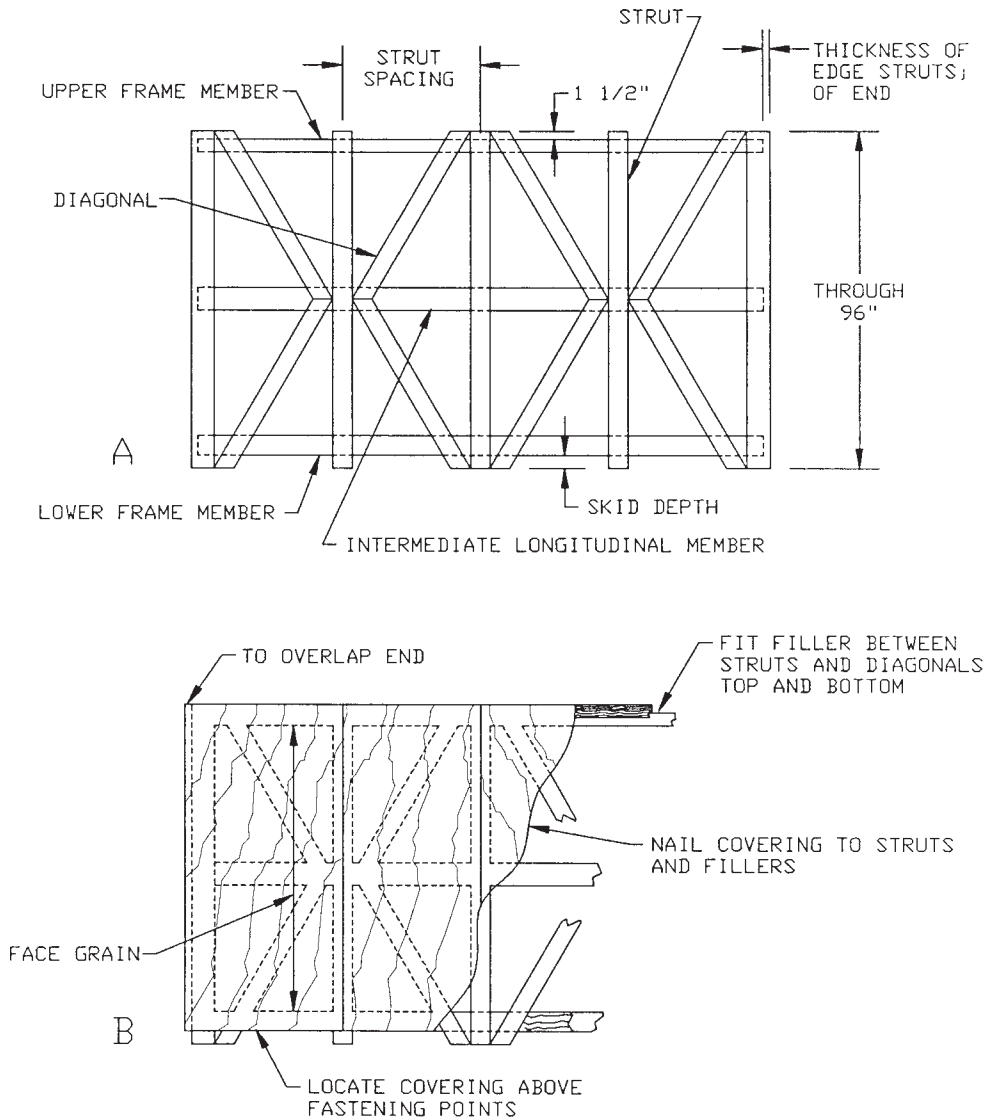

NOTE 1—A—open side; B—covered side.

FIG. 12 Double-Panel Sides for Type V, Style B Crates for Heights through 96 in.

barrier material suitable for crate liners, shall be placed under each covering joint. The strip shall extend across the full width of the top.

7.11.7 *Covered Crate Assembly*—The assembly of covered, Type V, Style B crates shall be as shown in Fig. 18 and the assembly requirements specified in 7.11.5, except for the following: Ninepenny nails, spaced 8 to 10 in. [200 to 250 mm] apart, shall be used through the covering to fasten: (1) the edge struts of the sides to the edge struts of the ends; (2) the struts, diagonals, and fillers of the sides to the edge longitudinal members of the top; (3) the end crossmembers of the top to the upper frame members of the ends; (4) the upper, lower, and horizontal members, diagonals, and fillers of the ends to the edge struts of the sides; (5) the lower frame members of the ends to the end headers of the base; and (6) the struts, diagonals, and fillers at the lower edge of the sides to the skids of the base. The covering of the top shall be nailed to the fillers of the sides with four penny nails, spaced 4 to 6 in. [100 to 150 mm] apart. When demountability is specified (see 5.1), the

sides and ends shall be fastened to the base with lag bolts as specified in 7.9.2.5.

7.12 *Assembly Instructions*—When specified (see 5.1), the contractor shall furnish applicable assembly instructions.

## 8. Tests

8.1 *Assembly Test*—A crate shall be completely assembled to ensure achievement of a container which can be properly and easily assembled, which is square, and is of the proper size. Evaluate the clarity and logic of the assembly instructions.

## 9. Shipping Preparation

9.1 Unless otherwise specified (see 5.1), the crates shall be furnished knocked down as top, base, side, and end panels. When knocked down, Type I, Style B crates shall consist of individual cut-to-length boards. Crates shall be shipped either assembled or unassembled and bundled, as specified (see 5.1). When bundled, component panels for one complete crate shall be secured together or a number of like panels (sides, ends,

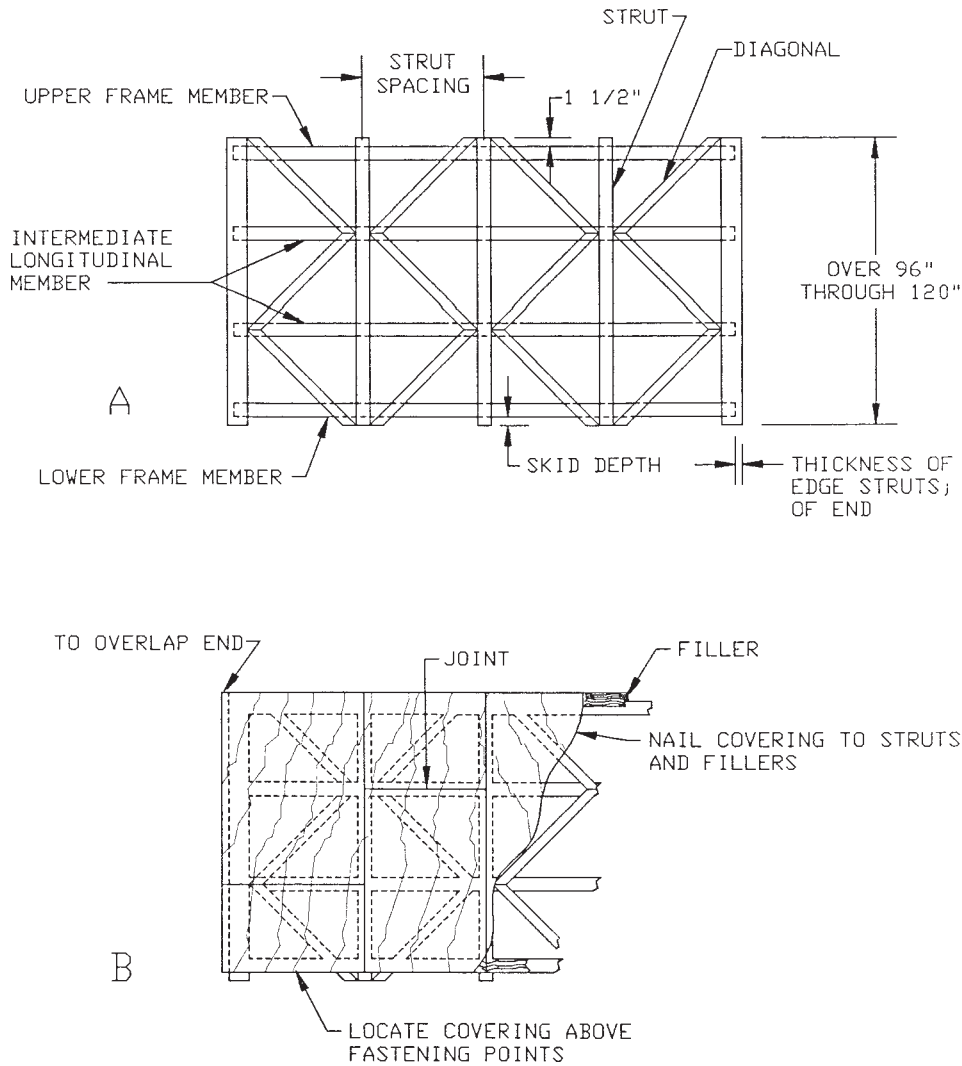

NOTE 1—A—open side; B—covered side.

FIG. 13 Triple-Panel Sides for Type V, Style B Crates for Heights Over 96 in.

base, etc.) shall be secured together, using strapping conforming to Specification D 3953, in a manner which will ensure carrier acceptance and safe delivery to destination at the lowest rating in compliance with Uniform Freight Classification rules or National Motor Freight Classification rules. Preserved assembly instructions, if required, shall be secured in a protected location on the bundle of complete crates or bundles of component panels.

9.2 The following marking requirements are mandatory for all shipments to the U.S. Government; they may be used for all other shipments:

9.2.1 *Special Marking*—Special marking shall be placed on the crate after closure as follows:

9.2.1.1 Center of balance location and a warning against use of hooks shall be in an appropriate location.

9.2.1.2 Type V, Style A and B demountable crates shall have each side marked “DEMOUNTABLE CRATE, REMOVE LAG BOLTS” in black letter not less than 1 in. [25 mm] high.

**10. Keywords**

10.1 crate; panels; shipping; wood

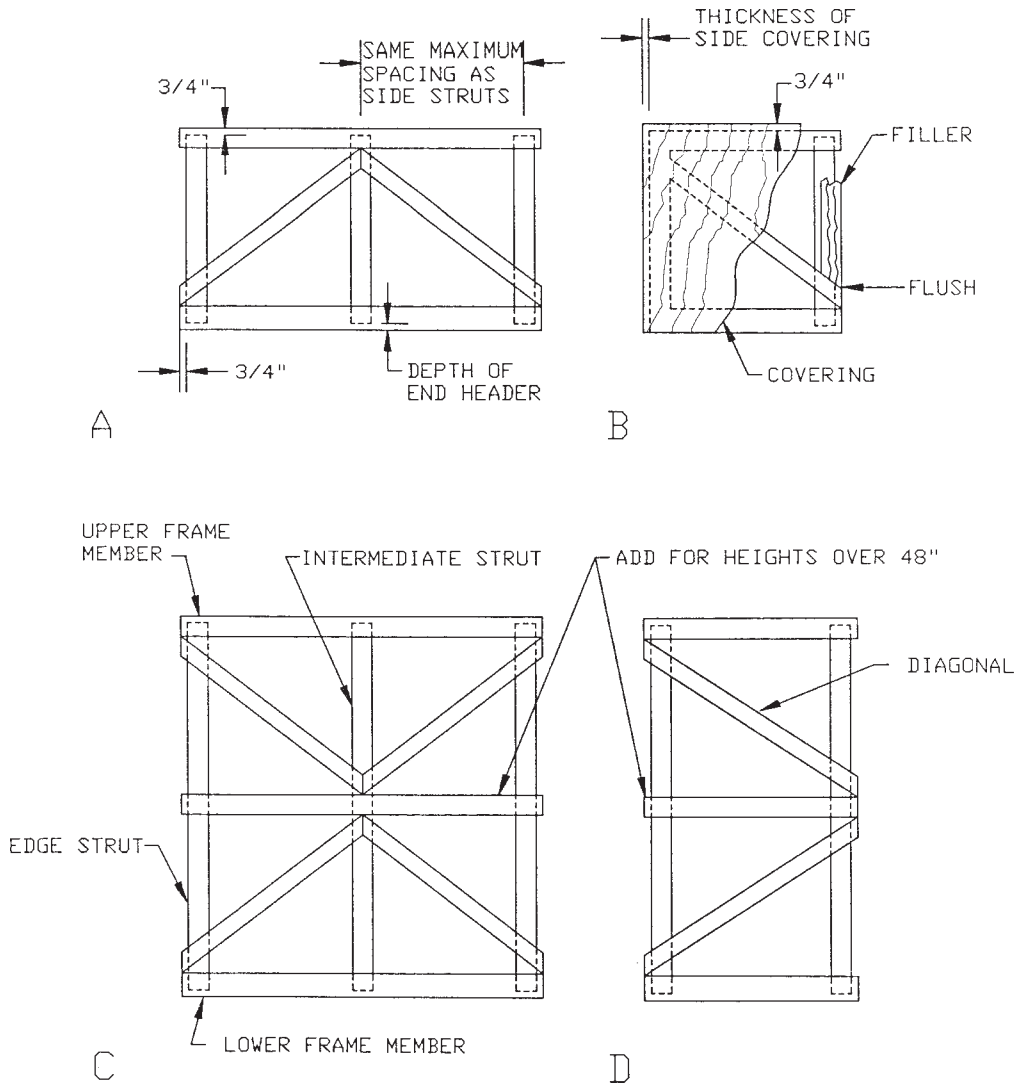

NOTE 1—A—two-panel horizontal; B—single-panel (covered); C—four-panel; D—two-panel vertical.  
**FIG. 14 Ends for Type V, Style B Crates**

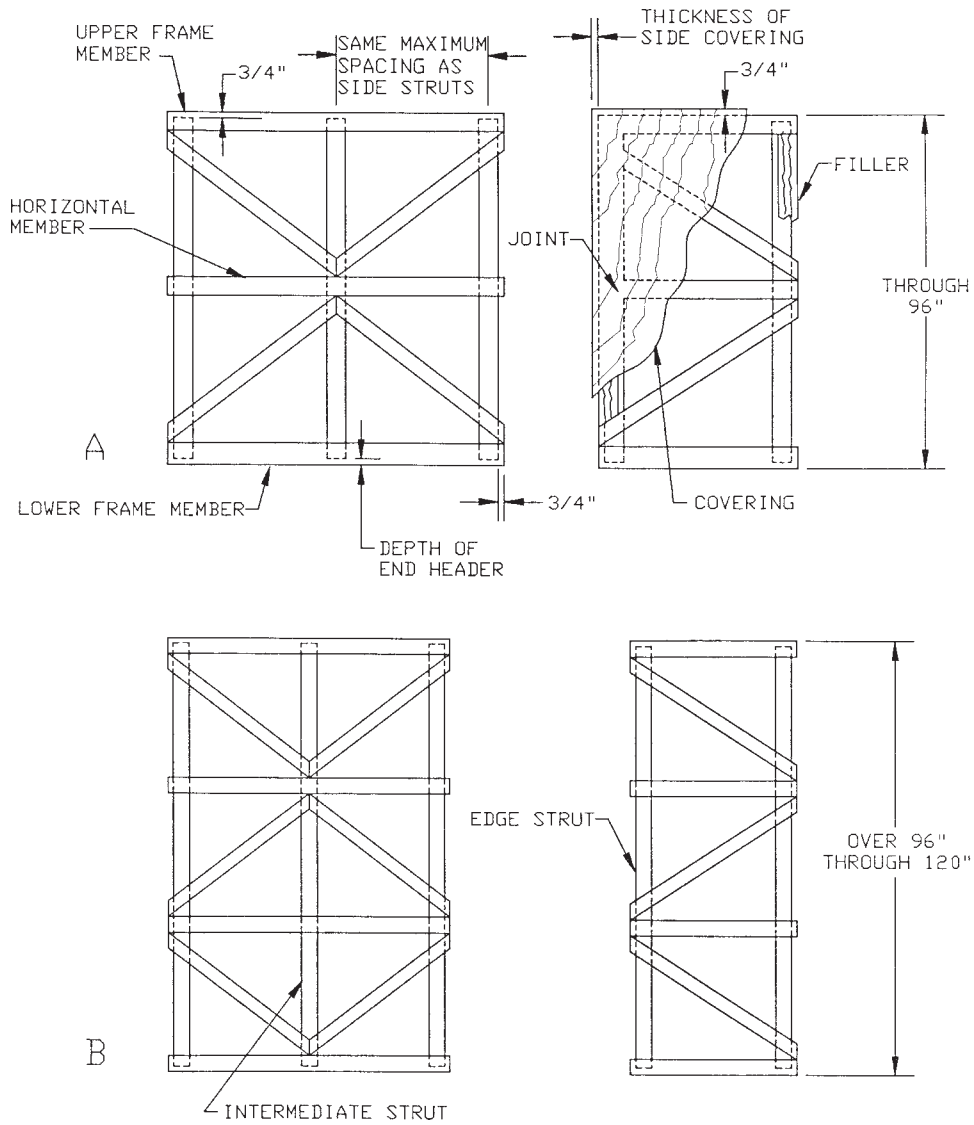

NOTE 1—A—wide and narrow double-panel ends; B—wide and narrow triple-panel ends.  
**FIG. 15 Ends for Type V, Style B Crates**



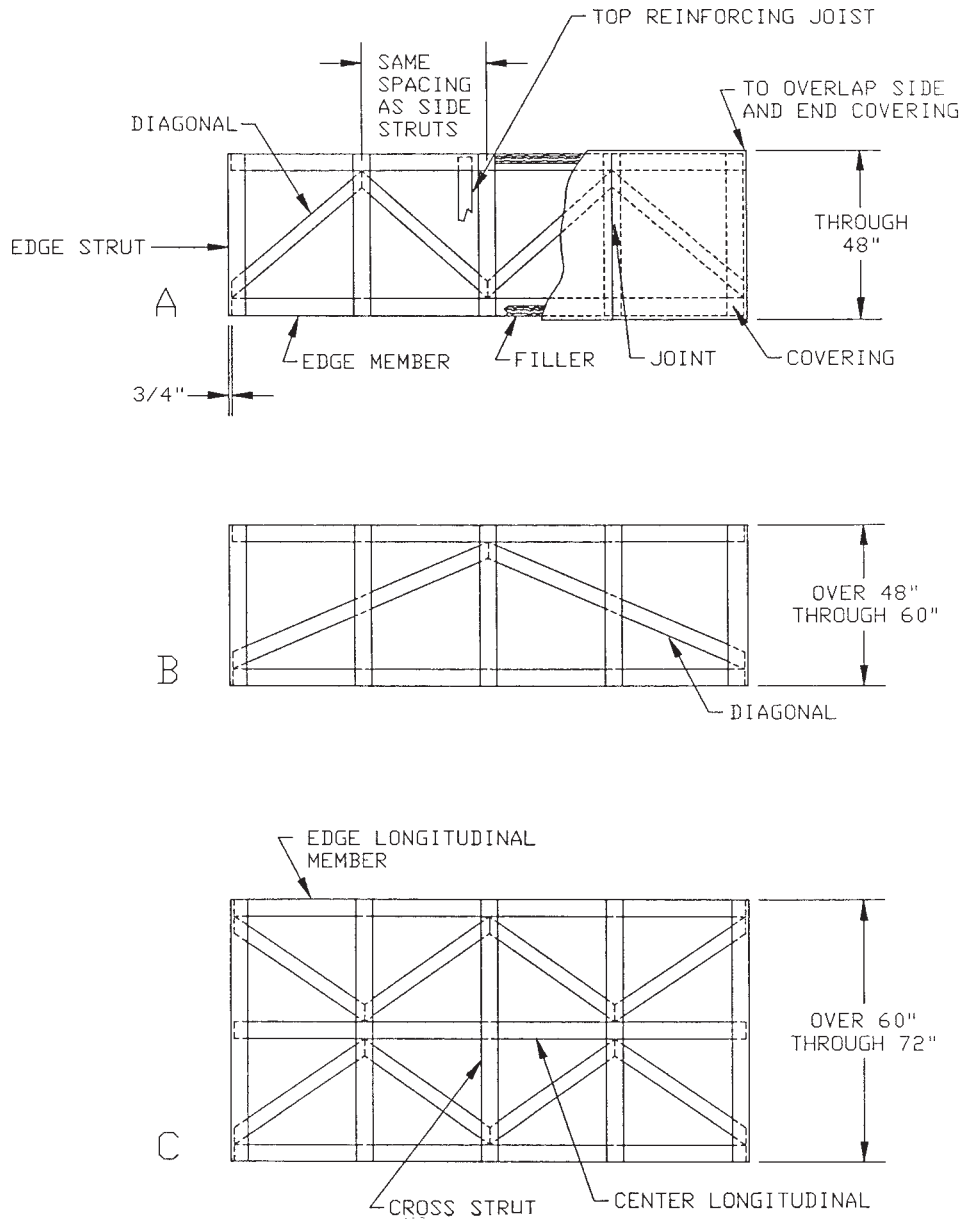

NOTE 1—A—narrow top; B—medium-wide top; C—wide top.

**FIG. 16 Tops for Type V, Style B Crates**

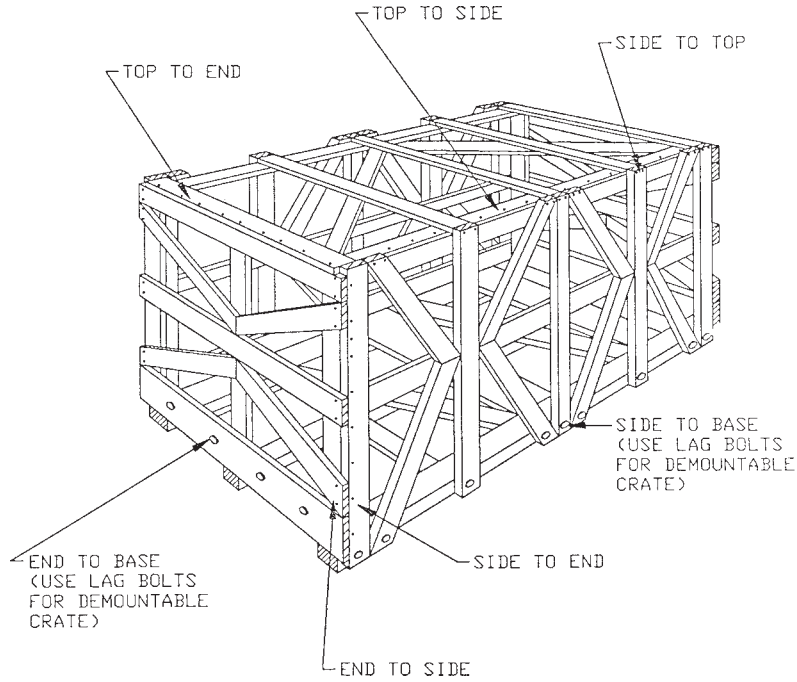

FIG. 17 Type V, Style B Crate Assembly (Open)

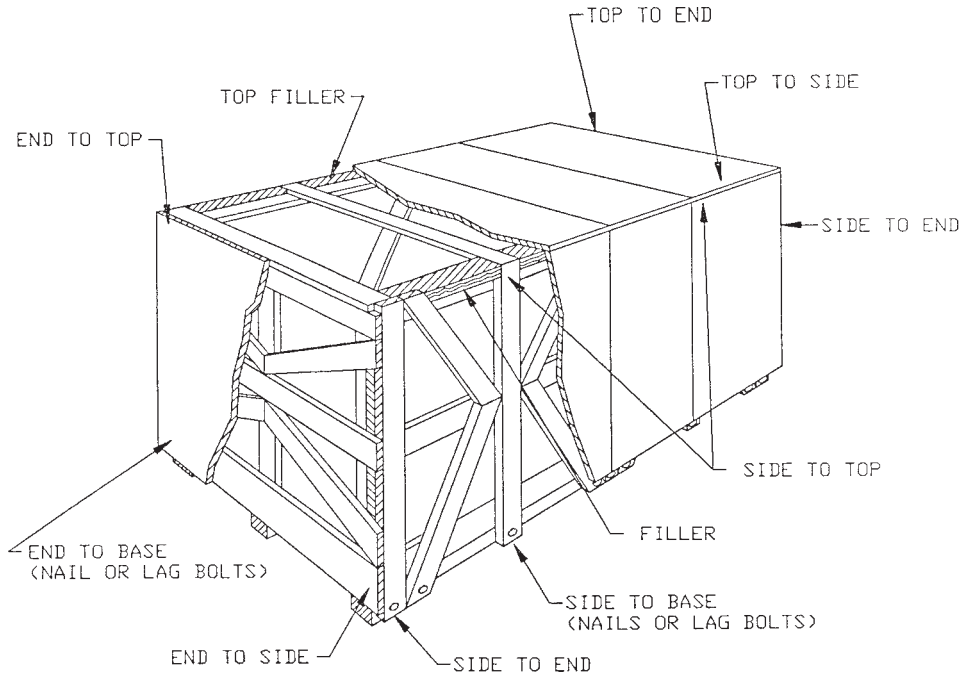

FIG. 18 Type V, Style B Crate Assembly (Covered)

TABLE 8 Tabulation of Skid Sizes

Net Load		Nominal Skid Size	
lb	[kg]	2 Skids	3 Skids
Up to 500	[Up to 225]	2 × 4 (flat)	2 × 4 (flat)
501 to 2000	[225 to 900]	3 × 4 (flat)	3 × 4 (flat)
2001 to 3000	[901 to 1350]	4 × 4	3 × 4 (flat)
3001 to 4000	[1351 to 1814]	4 × 4	4 × 4



**TABLE 9 Frame Member Sizes for Sides of Type V, Style B Crates**

Limits of Dimensions and Net Loads		Nominal Member Sizes						
Length, in. [mm]	Net Load, lb [kg]	Strut Spacing (On Center), max		Longitudinals			Struts	Diagonals
		Single Panel, in. [mm]	Double and Triple Panel, in. [mm]	Upper	Lower	Intermediate		
12 [300]	300 [135]	42 [1050]	42 [1050]	1 × 4	1 × 3	1 × 3	1 × 3 <sup>A</sup>	1 × 4
32 [800]	500 [225]	48 [1200]	54 [1350]	1 × 6	1 × 4	1 × 4	1 × 4 <sup>A</sup>	1 × 4
28 [700]	1000 [450]	42 [1050]	54 [1350]	1 × 6	1 × 4	1 × 4	1 × 4 <sup>A</sup>	1 × 4
24 [600]	2000 [900]	36 [900]	48 [1200]	1 × 6	1 × 6	1 × 6	1 × 6	1 × 6
20 [500]	3000 [1350]	36 [900]	48 [1200]	1 × 8	1 × 6	1 × 6	1 × 6 <sup>B</sup>	1 × 6 <sup>B</sup>
16 [400]	4000 [1814]	36 [900]	42 [1050]	1 × 8	1 × 8	1 × 8	1 × 8	1 × 8

<sup>A</sup>For edge struts, use 1 × 4 except that 1 × 6 members shall be used when edge struts of ends are 2 × 4 in. [50 × 100 mm] in size.

<sup>B</sup>For edge struts, use 1 × 8 members.

**TABLE 10 Number and Size of Lag Bolts Required to Assemble Sides to Base (Demountable Base) of Type V, Style B Crates**

Gross Weight (Crate and Contents) lb [kg]	Size of Bolts For Each Skid Size Total Minimum Number of Lag Bolts		
	<sup>5</sup> / <sub>16</sub> × 3 in. [8 × 75 mm] Bolt for Nominal 2 × 3 or 2 × 4 Skid (flat)	<sup>3</sup> / <sub>8</sub> × 3 in. [10 × 75 mm] Bolt for Nominal 3 × 3 Skid	<sup>1</sup> / <sub>2</sub> × 3 <sup>1</sup> / <sub>2</sub> in. [13 × 88 mm] Bolt for Nominal 4 × 4 or two 2 × 4 Skids (On Edge and Laminated)
1000 [450]	8	8	6
2000 [900]	14	10	10
3000 [1350]	18	16	12
4000 [1814]	24	20	14
5000 [2250]	30	26	18

ASTM International takes no position respecting the validity of any patent rights asserted in connection with any item mentioned in this standard. Users of this standard are expressly advised that determination of the validity of any such patent rights, and the risk of infringement of such rights, are entirely their own responsibility.

This standard is subject to revision at any time by the responsible technical committee and must be reviewed every five years and if not revised, either reapproved or withdrawn. Your comments are invited either for revision of this standard or for additional standards and should be addressed to ASTM International Headquarters. Your comments will receive careful consideration at a meeting of the responsible technical committee, which you may attend. If you feel that your comments have not received a fair hearing you should make your views known to the ASTM Committee on Standards, at the address shown below.

This standard is copyrighted by ASTM International, 100 Barr Harbor Drive, PO Box C700, West Conshohocken, PA 19428-2959, United States. Individual reprints (single or multiple copies) of this standard may be obtained by contacting ASTM at the above address or at 610-832-9585 (phone), 610-832-9555 (fax), or service@astm.org (e-mail); or through the ASTM website (www.astm.org).