



Standard Test Method for Evaluating Lubricity of Diesel Fuels by the Scuffing Load Ball-on-Cylinder Lubricity Evaluator (SLBOCLE)¹

This standard is issued under the fixed designation D 6078; the number immediately following the designation indicates the year of original adoption or, in the case of revision, the year of last revision. A number in parentheses indicates the year of last reapproval. A superscript epsilon (ϵ) indicates an editorial change since the last revision or reapproval.

1. Scope

1.1 This test method evaluates the lubricity (load carrying ability) of diesel fuels using a scuffing load ball-on-cylinder lubricity evaluator (SLBOCLE).

1.2 This test method is applicable to middle distillate fuels, such as Grades Low Sulfur No. 1 D, Low Sulfur No. 2 D, No. 1 D, and No. 2 D diesel fuels, in accordance with Specification D 975; and other similar petroleum-based fuels which can be used in diesel engines.

NOTE 1—It is not known that this test method will predict the performance of all additive/fuel combinations. Additional work is underway to further establish this correlation and future revisions of the standard may be necessary once this work is complete.

1.3 The values stated in SI units are to be regarded as the standard.

1.4 *This standard does not purport to address all of the safety concerns, if any, associated with its use. It is the responsibility of the user of this standard to establish appropriate safety and health practices and determine the applicability of regulatory limitations prior to use.* Specific hazard statements are given in Section 7.

2. Referenced Documents

2.1 ASTM Standards:

D 329 Specification for Acetone²

D 445 Test Method for Kinematic Viscosity of Transparent and Opaque Liquids (and the Calculation of Dynamic Viscosity)³

D 611 Test Method for Aniline Point and Mixed Aniline Point of Petroleum Products and Hydrocarbon Solvents³

D 770 Specification for Isopropyl Alcohol²

D 971 Test Method for Interfacial Tension of Oil Against Water by the Ring Method⁴

D 975 Specification for Diesel Fuel Oils³

D 1016 Test Method for Purity of Hydrocarbons from Freezing Points³

D 1133 Test Method for Kauri-Butanol Value of Hydrocarbon Solvents²

D 1218 Test Method for Refractive Index and Refractive Dispersion of Hydrocarbon Liquids³

D 1319 Test Method for Hydrocarbon Types in Liquid Petroleum Products by Fluorescent Indicator Adsorption³

D 4052 Test Method for Density and Relative Density of Liquids by Digital Density Meter⁵

D 4057 Practice for Manual Sampling of Petroleum and Petroleum Products⁵

D 4177 Practice for Automatic Sampling of Petroleum and Petroleum Products⁵

D 4306 Practice for Aviation Fuel Sample Containers for Tests Affected by Trace Contamination⁵

D 4367 Test Method for Benzene Content in Hydrocarbon Solvents by Gas Chromatography⁵

D 5001 Test Method for Measurement of Aviation Turbine Fuels by the Ball-on-Cylinder Lubricity Evaluator (BOCLE)⁵

D 6079 Test Method for Evaluating Lubricity of Diesel Fuels by the High-Frequency Reciprocating Rig (HFRR)⁶

2.2 *American Iron and Steel Institute Standard:*⁷

AISI E-52100 Chromium Alloy Steel

2.3 *American National Standards Institute Standard:*⁸

ANSI B3.12, Metal Balls

2.4 *Society of Automotive Engineers Standard:*⁹

SAE 8720 Steel

3. Terminology

3.1 *Definitions of Terms Specific to This Standard:*

3.1.1 *lubricity, n*—a qualitative term describing the ability of a fluid to affect friction between, and wear to, surfaces in relative motion under load.

¹ This test method is under the jurisdiction of ASTM Committee D02 on Petroleum Products and Lubricants and is the direct responsibility of Subcommittee D02.Eon Burner, Diesel, and Gas Turbine Fuels.

Current edition approved Nov. 10, 1999. Published December 1999. Originally published as D 6078 - 97. Last previous edition D 6078 - 97.

² *Annual Book of ASTM Standards*, Vol 06.04.

³ *Annual Book of ASTM Standards*, Vol 05.01.

⁴ *Annual Book of ASTM Standards*, Vol 10.03.

⁵ *Annual Book of ASTM Standards*, Vol 05.02.

⁶ *Annual Book of ASTM Standards*, Vol 05.03.

⁷ Available from American Iron and Steel Institute, 1000 16th St., NW, Washington, DC 20036.

⁸ Available from American National Standards Institute, 11 West 42nd St., 13th Floor, New York, NY 10036.

⁹ Available from Society of Automotive Engineers, 400 Commonwealth Ave., Warrendale, PA 15096.

3.1.1.1 *Discussion*—In this test method the lubricity of a fluid is evaluated by the minimum applied load in grams that, at any time during the test, will produce a friction coefficient greater than 0.175 between a stationary ball and a fluid-wetted rotating ring operating under defined conditions.

3.1.2 *boundary lubrication, n*—a condition in which the friction and wear between two surfaces in relative motion are determined by the properties of the surfaces and the properties of the contacting fluid, other than bulk viscosity.

3.1.2.1 *Discussion*—Metal-to-metal contact occurs and the chemistry of the system is involved. Physically adsorbed or chemically reacted soft films (usually very thin) support contact loads. As a result some wear is inevitable.

3.1.3 *applied load, n*—the weight in grams added to the load arm of the SLBOCLE unit.

3.1.4 *contact load, n*—the force in grams with which the ball contacts the test ring.

3.1.4.1 *Discussion*—For the SLBOCLE cantilever system the contact load is two times the applied load.

3.1.5 *scuffing, n—in lubrication*, damage caused by instantaneous localized welding between surfaces in relative motion which does not result in immobilization of the parts.

3.1.6 *scuffing load, n*—the load required to produce scuffing of surfaces.

3.1.6.1 *Discussion*—For this test method the scuffing load is defined in terms of the applied load.

3.1.7 *friction trace, n*—a recorded trace of the tangential friction force in grams.

3.1.8 *friction coefficient, n*— tangential friction force divided by the contact load.

4. Summary of Test Method

4.1 A 50-mL test specimen of fuel is placed in the test reservoir of an SLBOCLE and adjusted to the test temperature of 25°C.

4.2 When the fuel temperature has stabilized, 50 % relative humidity air is used to aerate the fuel at 0.5 L/min while 3.3 L/min flows over the fuel for 15 min. During the remainder of the test sequence, the 50 % relative humidity air flows over the fuel at a rate of 3.8 L/min.

4.3 A load arm holding a non-rotating steel ball and loaded with a 500 g mass is lowered until it contacts a partially fuel immersed polished steel test ring rotating at 525 rpm. The ball is caused to rub against the test ring for a 30-s break in period before beginning an incremental-load or a single-load test.

4.4 Wear tests are conducted by maintaining the ball in contact with the partially immersed 525- rpm test ring for 60 s. For incremental load tests, the test ring is moved at least 0.75 mm for each new load prior to bringing a new ball into contact with the test ring.

4.5 The tangential friction force is recorded while the ball is in contact with the test ring. The friction coefficient is calculated from the tangential friction force.

4.6 In the incremental-load test, the minimum applied load required to produce a friction coefficient greater than 0.175 is an evaluation of the lubricating properties of the diesel fuel.

4.7 In the single-load test, a friction coefficient less than or equal to 0.175 indicated the diesel fuel passes the lubricity evaluation, while a friction coefficient greater than 0.175 indicated the diesel fuel fails the lubricity evaluation.

5. Significance and Use

5.1 Diesel fuel injection equipment has some reliance on lubricating properties of the diesel fuel. Shortened life of engine components, such as diesel fuel injection pumps and injectors, has sometimes been ascribed to lack of lubricity in a diesel fuel.

5.2 The trend of SLBOCLE test results to diesel injection system pump component distress due to wear has been demonstrated in pump rig tests for some fuel/hardware combinations where boundary lubrication is believed to be a factor in the operation of the component.¹⁰

5.3 The tangential friction force, as measured in the SLBOCLE test, is sensitive to contamination of the fluids and test materials, the presence of oxygen and water in the atmosphere, and the temperature of the test. Lubricity evaluations are also sensitive to trace contaminants acquired during test fuel sampling and storage.

5.4 The SLBOCLE and High-Frequency Reciprocating Rig (HFRR, Test Method D 6079) are two methods for evaluating diesel fuel lubricity. No absolute correlation has been developed between the two test methods.

5.5 The SLBOCLE may be used to evaluate the relative effectiveness of diesel fuels for preventing wear under the prescribed test conditions. If a standard SLBOCLE rating has been set, then the single-load test provides a more rapid evaluation than the incremental load test. Correlation of SLBOCLE test results with field performance of diesel fuel injection systems has not yet been determined.

5.6 This test method is designed to evaluate boundary lubrication properties. While viscosity effects on lubricity in this test method are not totally eliminated, they are minimized.

6. Apparatus

6.1 *Scuffing Load Ball-on-Cylinder Lubricity Evaluator (SLBOCLE)*:

6.1.1 The SLBOCLE consists of a fluid reservoir in which a cylinder rotates, a load arm to which a ball is attached, and a hanger to hang a load on the load arm. The SLBOCLE^{11,12} illustrated in Fig. 1 and Fig. 2 is identical to the ball-on-cylinder lubricity evaluator (BOCLE) specified in Test Method D 5001, except for the modifications in 6.1.2 through 6.1.4. Complete operating conditions are listed in Table 1.

¹⁰ Nikanjam, M., Crosby, T., Henderson, P., Gray, C., Meyer, K., and Davenport, N., "ISO Diesel Fuel Lubricity Round Robin Program, SAE Paper No. 952372, SAE Fuels and Lubricants Meeting, October 16–19, 1995, Toronto, Canada.

¹¹ SLBOCLE units, BOC-2000, available from InterAv, P.O. Box 792228, San Antonio, TX 78279, have been found satisfactory.

¹² The sole source of supply of the apparatus known to the committee at this time is provided. If you are aware of alternative suppliers, please provide this information to ASTM Headquarters. Your comments will receive careful consideration at a meeting of the responsible technical committee¹, which you may attend.

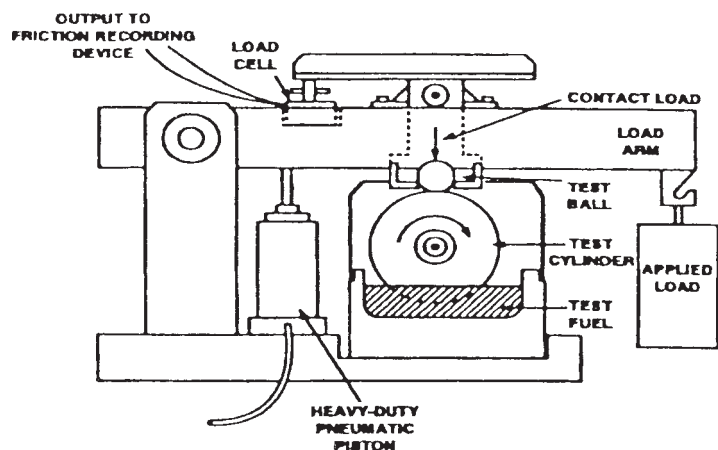

FIG. 1 Schematic Diagram of the Scuffing Load Ball-on-Cylinder Lubricity Evaluator (not including instrumentation)

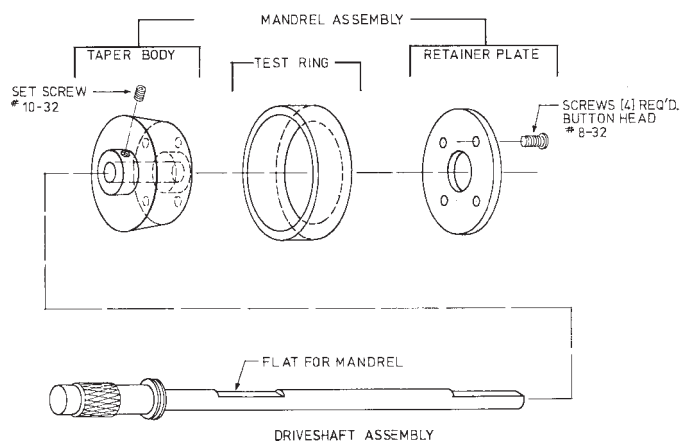

FIG. 2 Ring and Mandrel Assembly (Cylinder)

TABLE 1 Test Conditions

| Parameter | Value |
|---|---------------------------------------|
| Fluid volume | 50 ± 1.0 mL |
| Fluid temperature | 25 ± 1°C |
| Conditioned air ^A | 50 ± 1% relative humidity at 25 ± 1°C |
| Fluid pretreatment: 0.50 L/ min air flowing through and 3.3 L/min air flowing over the fluid for 15 min | |
| Fluid test conditions: 3.8 L/min air flowing over the fluid | |
| Cylinder rotational speed | 525 ± 1 rpm |
| Applied Load | |
| Break-in period | 500 g |
| Incremental-load test | 500 to 5 000 g |
| Single-load test | user defined ^B |
| Test Duration | |
| Break-in period | 30 s |
| Wear tests | 60 s |

^A Fifty percent humidity should be achieved using equal volumes of dry and saturated air. The SLBOCLE has a water column through which air passes and it is assumed to be saturated when it exits this column.

^BThe applied load for the single test is set at the pass/fail requirement for the fuel being evaluated

6.1.2 If a standard BOCLE machine is modified, a load cell is included to accurately measure tangential friction force with output to a recording device.^{12,13}

6.1.3 If a standard BOCLE machine is modified, a redesigned reservoir cover or splash guards is necessary to prevent loss of fluid from the joint between the reservoir cover and reservoir.^{12,14}

6.1.4 If standard BOCLE machine is modified, a heavy-duty pneumatic piston is required to facilitate the increased loads required in the SLBOCLE test.^{12,15}

6.1.5 *Cylinder*, the polished test ring and mandrel assembly. See Fig. 2.

6.1.6 *Mandrel*, a 10° tapered short cylindrical section used for holding test ring.^{12,16} See Fig. 2

6.2 *Constant Temperature Bath Circulator*, capable of maintaining the fluid sample at 25 ± 1°C when circulating coolant through the base of the sample reservoir.

6.3 *Cleaning Bath*, ultrasonic seamless stainless steel tank with adequate capacity and a cleaning power of 40 W or greater.

6.4 One of the containers specified under Containers for Lubricity Testing in Practice D 4306 shall be used to store and transport fuel samples.

6.5 *Desiccator*, containing a non-indicating drying agent, capable of storing test rings, balls, and hardware.

7. Reagents and Materials

7.1 *Acetone*, (**Warning:** Extremely flammable. Vapors may cause flash fire.) conforming to Specification D 329.

7.2 *Compressed Air*, (**Warning:** Compressed gas under high pressure. Use with extreme caution in the presence of combustible material.) containing less than 0.1 ppmv hydrocarbons and 50 ppmv water.

7.3 *Gloves*, clean, lint-free, cotton, disposable.

7.4 *Isooctane*, (**Warning:** Extremely flammable. Harmful if inhaled. Vapors may cause flash fires.) conforming to Test Method D 1016, 95 % purity minimum, 2,2,4-trimethylpentane.

7.5 *Isopropyl Alcohol*, (**Warning:** Flammable.) conforming to Specification D 770.

7.6 *Reference Fluids:*

7.6.1 *Fluid A*—High lubricity reference¹⁷ (**Warning:** Flammable.) Store in clean, borosilicate glass with an aluminum foil-lined insert cap. Store in a dark area.

7.6.2 *Fluid B*—Low lubricity reference¹⁷ (**Warning:** Flammable. Vapor harmful.)

7.7 *Test Ball*, chrome alloy steel, made from AISI standard steel No. E-52100, with a diameter of 12.7 mm, Grade 5 to 10 EP finish. The balls are described in ANSI Specification B3.12. The extra-polish finish is not described in that specification.

¹⁴ Catalog No. BOC-217-A, available from InterAv, Inc., P.O. Box 792228, San Antonio, TX 78279, has been found satisfactory.

¹⁵ Catalog No. BOC-215-15, available from InterAv, Inc., P.O. Box 792228, San Antonio, TX 78279, has been found satisfactory.

¹⁶ Mandrel, Part No. M-O, available from Falex Corp., or P/N BOC-2101, available from InterAv, Inc., P.O. Box 792228, San Antonio, TX 78279, has been found satisfactory.

¹⁷ Reference fluids A and B are available from ASTM Test Monitoring Ctr., 6555 Penn Ave., Pittsburgh, PA 15026-4489.

¹³ Catalog No. BOC-2040-FFC, available from InterAv, Inc., P.O. Box 792228, San Antonio, TX 78279, has been found satisfactory.

The Rockwell hardness “C” scale (HRC) shall be 64 to 66, a closer limit than found in the ANSI requirement.^{12,18}

7.8 *Test Ring*, of SAE 8720 steel, having HRC number of 58 to 62 and a surface roughness between 0.04 and 0.15 μm after polishing as described in A1.1.^{12,19} The dimensions are given in Fig. 3.

7.9 *Wiper*, wiping tissue, light-duty, lint-free, hydrocarbon-free, disposable.^{12, 20}

8. Sampling and Sample Containers

8.1 Unless otherwise specified, samples shall be taken by the procedure described in Practice D 4057 or Practice D 4177.

8.2 Because of the sensitivity of lubricity measurements to trace materials, sample containers shall be only fully epoxy-lined metal, amber borosilicate glass, or polytetrafluorethylene (PTFE), cleaned and rinsed thoroughly at least three times with the product to be sampled before use, as specified under Containers for Lubricity Testing in Practice D 4306.

8.3 New sample containers are preferred, but if not available the Containers for Lubricity Testing section of Practice D 4306 gives guidance on suitable cleaning procedures for each type of container.

9. Preparation of Apparatus

9.1 *Test Rings*, (as received):

¹⁸ Test Balls, SKF Swedish, Part No. 310995A, RB 12.7, grade 5 to 10 EP Finish, AISI 52100 Alloy available from SKF Industries, Component Systems, 1690 East Race St., Allentown, PA 90653, when requested with extra polish finish, have been found satisfactory.

¹⁹ Test Rings, Part No. TRXP-6 available from U.S. Army TARDEC Fuels and Lubricants Research Facility, P.O. Drawer 28510, San Antonio, TX 78228-0510 have been found satisfactory. These rings are Part No. F25061 from Falex Corp., 1020 Airpark Dr., Sugar Grove, IL 60554-9585, polished to the required surface finish by the method in Annex A3. Correct surface finish is central to test accuracy.

²⁰ Blue Wipe, Catalog No. C6415-31 available from Baxter Healthcare Corp., 210 Great Southwest Pkwy, Grand Prairie, TX 75050, has been found satisfactory.

9.1.1 If test rings are covered with a wax-like protective coating or with grease, then strip this coating off by rubbing them with a clean paper towel saturated with *isooctane*.

9.1.2 Place rings in a clean beaker. Transfer a sufficient volume of a 1 to 1 mixture of *isooctane* and isopropyl alcohol to the beaker so that the test rings are completely covered.

9.1.3 Place the beaker in ultrasonic cleaner and turn on for 15 min.

9.1.4 Remove the test rings and repeat the ultrasonic cleaning cycle of 9.1.1.1 and 9.1.1.2 with a clean beaker and fresh solvents.

9.1.5 Handle all clean test rings with clean forceps. Remove test rings from beaker and rinse with *isooctane*, dry and rinse with acetone.

9.1.6 Dry and store in a desiccator.

NOTE 2—The parts can dry by sitting until the acetone has evaporated or the drying can be speeded up using a compressed air (7.2) jet at 140 to 210 kPa pressure.

9.2 *Test Balls*, (as received):

9.2.1 Place balls in a clean beaker. Transfer a sufficient volume of a 1 to 1 mixture of *isooctane* and isopropyl alcohol to the beaker so that the test balls are completely covered by the cleaning solvent.

9.2.2 Place the beaker in the ultrasonic cleaner and turn on for 15 min.

9.2.3 Repeat the cleaning cycle of 9.1.2.1 and 9.1.2.2 with a clean beaker and fresh solvent.

9.2.4 Remove and rinse with *isooctane*; dry and rinse with acetone.

9.2.5 Dry and store in a desiccator.

9.3 *Reservoir, Reservoir Cover, Ball Chuck, Ball Lock Ring, and Ring Mandrel Assembly Components*:

9.3.1 Rinse with *isooctane*.

9.3.2 Clean for 5 min. in an ultrasonic cleaner with a 1 to 1 mixture of *isooctane* and isopropyl alcohol.

9.3.3 Remove and rinse with *isooctane*, dry and rinse with acetone.

9.3.4 Dry and store in a desiccator.

9.4 *Hardware*:

9.4.1 The hardware and utensils (drive shaft, wrenches, and tweezers) that come in contact with the test fluid shall be cleaned by washing thoroughly with *isooctane* and wiping with a lint-free cloth.

9.4.2 Store parts in a desiccator when not in use.

9.5 *After Test*:

9.5.1 Remove reservoir and cylinder.

9.5.2 Disassemble components and clean for 5 min in an ultrasonic cleaner using a 1 to 1 mixture of *isooctane* and isopropyl alcohol. Rinse with *isooctane*, dry, and rinse with acetone. Reassemble components.

9.5.3 Dry and store in a desiccator.

9.5.4 Exercise care to ensure that the fuel aeration tube is rinsed and dried during the cleaning procedure. Store parts in a desiccator when not in use.

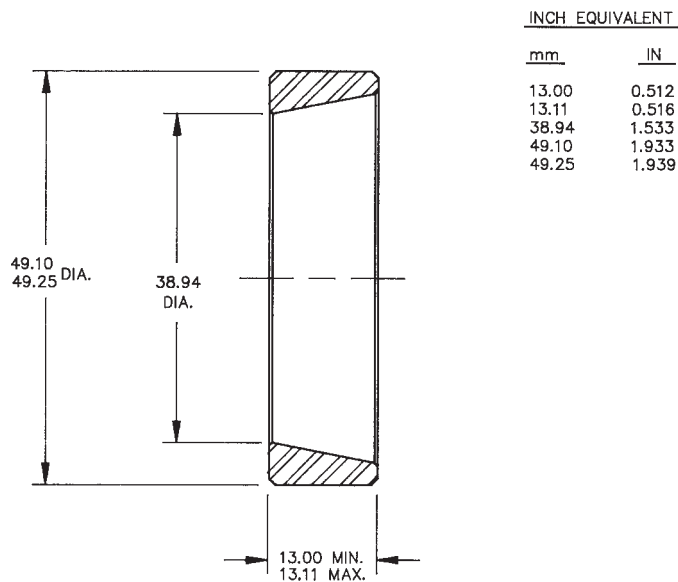

FIG. 3 SLBOCLE Test Ring

10. Test Apparatus Inspection and Verification

10.1 *Inspection*—Visually inspect, with the naked eye, test balls and rings before each test. Discard specimens that exhibit pits, corrosion, or surface abnormalities.

10.2 Reference Fluids:

10.2.1 Test each new batch of the reference fluids as follows:

10.2.2 Verify test performance and accuracy at least once every twelve fuels, at the two loads provided with reference fluids A and B.

10.2.3 Calculate the maximum friction coefficient for each applied load in accordance with Section 13.

10.2.4 Additional tests are necessary if the applied load in grams on Reference Fluids A or B lie outside the acceptable range as discussed in 10.2.5.

10.2.5 Acceptable ranges for the lubricity values of reference fluids will be determined by an interlaboratory round robin and will be provided with each fluid at the time of purchase.

10.3 Leveling of Load Arm:

10.3.1 The level of the load arm shall be inspected prior to each test. Level the motor platform by use of the circular bubble level and adjustable stainless steel legs.

10.3.2 Install a test ball in the retaining nut as described in 11.3.

10.3.3 Disengage the load arm pull pin and lower the load arm. Attach required weight to end of load beam. Lower ball onto ring manually.

10.3.4 Check level on top of load arm. The indicator bubble shall be centered in the middle of the two lines. If required, adjust the retaining nut screw to achieve a level load arm.

10.4 Assembly of Cylinder:

10.4.1 Place a clean test ring on the mandrel and bolt the back plate to the mandrel.

11. Procedure A, Incremental-Load Test

11.1 Install Cleaned Test Cylinder:

NOTE 3—The SLBOCLE is very sensitive to contamination problems.

11.1.1 Adhere strictly to cleanliness requirements and to the specified cleaning procedures. During handling and installation procedures, protect cleaned test parts (cylinder, balls, reservoir, and reservoir cover) from contamination by wearing clean cotton gloves.

11.1.2 Secure the load beam in the UP position by inserting the load arm pull pin.

11.1.3 Push the drive shaft through the left-hand bearing and support bracket.

11.1.4 Hold the cylinder with the set screw hub facing left. Push the drive shaft through the cylinder bore, through the right-hand bearing support bracket, and into the coupling as far as the drive shaft will go.

11.1.5 Align the coupling set screw with the flat keyway side of the cylinder drive shaft. Tighten set screw.

11.2 Position Cylinder:

11.2.1 For a new cylinder, set the micrometer at 2.50 mm and slide cylinder to the left until it is firmly against micrometer probe. Ensure that cylinder set screw is directed toward the keyway (flat surface of drive shaft) and tighten set screw. This

should position the first wear track on a ring approximately 1 mm in from the left side. If a cylinder used for a previous fuel is being used, then position the new wear track at least 0.75 mm to the right of the last track on the ring.

11.2.2 Back micrometer probe away from the cylinder before the drive motor is engaged.

11.2.3 Record on the data sheet the ring number, if assigned, and the position of the test cylinder as indicated by the micrometer. The first and last wear tracks on a ring shall be approximately 1 mm in from either side.

11.3 Install a clean test ball by first placing the ball in the retaining nut, followed by the retaining ring. Screw the retaining nut onto the threaded chuck located on the load arm and hand tighten.

11.4 Install the clean reservoir. Install the spacing platform by raising the reservoir. Slide the spacer platform into position under the reservoir. Place the thermocouple in the hole provided at the rear left side of the reservoir.

11.5 Supply test fluid in accordance with Practice D 4306. Transfer 50 ± 1 mL of the test fluid to the reservoir. Place the cleaned reservoir cover in position and attach the 1/4 to 1/8-in. air lines to the reservoir cover.

11.6 Move the power switch to the ON position.

11.7 Adjust the reservoir temperature, as required, until temperature stabilizes at $25 \pm 1^\circ\text{C}$. Adjust thermostat of the heat exchanger circulating bath to obtain the required temperature.

11.8 Turn on the compressed air cylinder. Adjust the delivery pressure to 350 kPa and the console air pressure to 200 kPa.

NOTE 4—At loads above 4500 g, manual assist may be necessary.

11.9 Place lift actuator switch in the UP position.

11.10 Using the flowmeters that control the wet and dry airflows, adjust total airflow to read 3.8 L/min. Maintain $50 \pm 2\%$ relative humidity.

NOTE 5—Fifty percent relative humidity requires approximately equal volumes of wet and dry air.

11.11 Set fuel aeration timer for 15 min and adjust fuel aeration flowmeter to 0.5 L/min.

11.12 At completion of aeration, the whistle will sound and aeration will cease. Continue 3.8 L/min flow through the reservoir.

11.13 Break-In:

11.13.1 Place the 500-g load on the load arm.

11.13.2 Remove the load arm pull pin and gently lower load arm until the complete load is supported by the pneumatic piston. Do not allow the ball specimen to contact the ring.

11.13.3 Start rotation of cylinder by switching motor drive to ON. Set rotation to 525 rpm.

11.13.4 Move actuator switch to DOWN position. The load arm will lower and the ball will contact the test ring.

11.13.4.1 The lift arm actuator valve on the side of the cabinet controls the rate at which the load arm lowers. The valve controls the bleed from the pneumatic lift cylinder. Adjust the valve so that the full load is applied to the ball and contact between the pneumatic lift cylinder and load arm ceases after 5 s.

11.13.5 Switch the timer on for 30 s.

11.13.6 When the whistle sounds at the end of 30 s, immediately remove the test load, manually raise the load arm and insert the load arm pull pin. do not rely on the pneumatic lift cylinder to life the load arm.

11.13.7 Place the lift actuator switch in the UP position.

11.14 *Incremental-Loads:*

11.14.1 Place 2800 g load on load arm.

11.14.2 Remove the load arm pull pin and gently lower the load arm until the complete load is supported by the pneumatic piston. Do not allow the ball specimen to contact the ring.

11.14.3 Start rotation of the the cylinder by switching motor drive to ON. Set rotation to 525 ± 1 rpm.

11.14.4 Switch on the recording device for friction trace output.

11.14.5 Check all test condition readouts and adjust as necessary. Record all necessary information on the data sheet.

11.14.6 Move the actuator switch to the DOWN position. The load arm will lower and the ball will contact the ring.

11.14.7 Switch the timer on for 60 s.

11.14.8 When the whistle sounds at the end of 60 s, immediately remove the test load, manually raise the load arm, and insert the load arm pull pin. Do not rely on the pneumatic lift cylinder to lift the load arm. If severe vibration or severe changes in sounds are evident, terminate the test prior to completion of the 60 s.

11.14.9 Place the lift actuator switch in the UP position.

11.14.10 Turn the motor drive switch to the off and switch off recording device. Manually rotate motor shaft and wipe the revolving ring with an UNUSED disposable, lint-free cloth to remove residue from the test ring.

11.14.11 Remove the test ball from the locking nut. Wipe the ball clean with a disposable wipe. Replace with a new ball as described in 11.3.

11.14.12 Calculate the MAXIMUM friction coefficient as described in Section 14 Typical plots of friction coefficient versus time, where the maximum friction coefficient does and does not exceed 0.175, are shown in Fig. 4.

11.14.13 Loosen the coupling set screw, NOT the mandrel set screw, and reset the cylinder to a new test position at least 0.75 mm from the last track by adjusting the micrometer. The reservoir cover is not removed to loosen the mandrel set screw after the initial aeration is completed to minimize atmospheric contamination between tests.

11.14.14 The maximum number of loads per ring is 15.

11.14.15 Based on the maximum friction coefficient and Fig. 5, choose the next load increment and repeat the testing sequence from 11.13 through 11.14.13 except for substituting the new load for the 2800 g load in 11.14.1.

11.14.16 Terminate the incremental-load tests when the applied load for a maximum friction coefficient exceeding and not exceeding 0.175 differs by 100 g.

11.14.17 Repeat the test procedure from 11.1 with a different, precleaned test ring to verify the initial result. This does not constitute a duplicate result because a new sample of the fuel has not been used.

11.14.17.1 Do NOT replace or aerate the test fluid unless the total number of test increments performed with that fluid exceeds twelve.

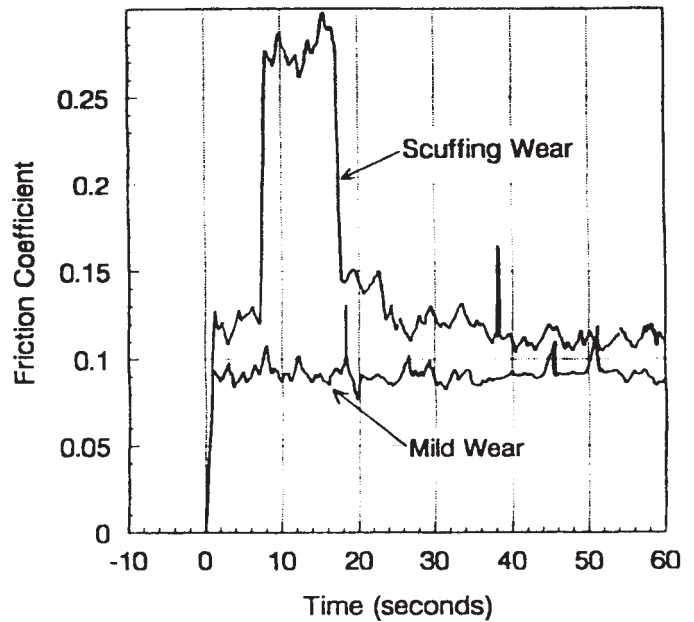

FIG. 4 Typical Friction Coefficients Obtained During Load Wear Tests — Calculated from Friction Trace Recording

11.14.17.2 For the repeat test procedure, more rapid convergence *may* be obtained by using load increments near to the previously obtained result.

11.14.17.3 If the two test results differ by 500 g, or more, the results are not reliable and should be discarded. The complete test procedure detailed in Section 10 should be repeated until two test results are within 500 g.

12. Procedure B, Single-Load Test

12.1 If one selects an applied load which is considered to represent a minimum acceptable level, that is, a level at which no scuffing should be observed, then a single-load test can be conducted at this applied load.

12.2 Prepare, calibrate, and standardize the equipment as described in Sections 9 and 10.

12.3 Follow the procedure given in 11.1 through 11.13.7.

12.4 Place the selected load on the load arm.

12.5 Follow the procedure given in 11.14.2 through 11.14.12

12.6 If the maximum friction coefficient from 11.14.12 is less than or equal to 0.175, the fuel is considered to have passed at the selected load.

12.7 If the maximum friction coefficient from 11.14.12 is greater than 0.175, the fuel is considered to have failed due to scuffing at the selected load.

13. Measurement of Friction

13.1 *Friction Measurement*—Read and record the *maximum* tangential friction force in grams from the friction trace recording.

14. Calculation

14.1 Calculate the maximum friction coefficient as follows:

$$\mu_m = \frac{F_t}{2F_a} \quad (1)$$

Rules

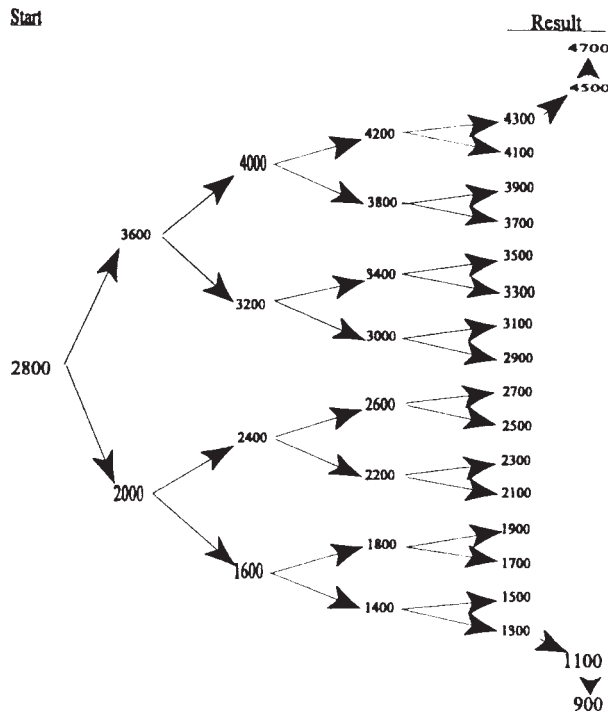

NOTE 1—The following rules apply:

- (1) Move left to right when selecting load, start at 2800 g.
- (2) If maximum friction coefficient exceeds 0.175, select the next lower load to the right (that is, follow the downward arrow.)
- (3) If maximum friction coefficient is less than 0.175, select the next higher load to the right (that is, follow the upward arrow.)
- (4) The result is the lowest load at which the maximum friction coefficient exceeds 0.175, reported to the nearest 100 g.
- (5) If necessary, additional tests may be performed to assess results outside the range 1300 to 4300 g. However, few fuels exceed the given range.

FIG. 5 Incremental Load Test Sequence

where:

- μ_m = maximum friction coefficient,
- F_t = maximum tangential friction force, g, from friction trace recording, and
- F_a = applied load, g.

15. Report

15.1 Report the following information:

15.1.1 *For Procedure A, Incremental-Load Test:*

15.1.1.1 Report the average of the applied loads in grams determined in 11.14.16 and 11.14.17 for which the maximum friction coefficient exceeds 0.175.

- 15.1.1.2 Description of the test fuel and date of sampling.
- 15.1.1.3 Date of testing.
- 15.1.1.4 Any deviation from the test condition given in Table 1.

15.1.2 *For Procedure B, Single-Load Test:*

15.1.2.1 The selected applied load in grams and the maximum friction coefficient during the single-load test from 11.14.12.

15.1.2.2 Whether the fluid passed or failed the lubricity evaluation at the selected applied load.

15.1.2.3 Description of the test fuel and date of sampling.

15.1.2.4 Date of testing.

15.1.2.5 Any deviations from the test conditions given in Table 1.

16. Precision and Bias ²¹

16.1 *Precision*—The precision was developed for fuels with SLBOCLE’s between 1100 and 6200 g. The precision data were developed in a 1995 cooperative testing program involving both United States and European testing laboratories. There were 9 distinct fluids and each laboratory was given 18 fluids to test. The fluids were blind coded so that replicate samples were not known to the operator. A randomized test sequence was provided and each laboratory was requested to use the same operator and equipment for all 18 samples. Nine laboratories participated in this round robin.

16.1.1 The difference between two test results obtained by the same operator with the same apparatus under constant operating conditions on identical test material would, in the long run, in the normal and correct operation of this test method, exceed the following value in only one case in twenty:

$$\text{Repeatability} = 900 \text{ g}$$

16.1.2 The difference between two single and independent results obtained by different operator working in different laboratories on identical test material would, in the long run, in the normal and correct operation of this test method, exceed the following value in only one case in twenty:

$$\text{Reproducibility} = 1500 \text{ g}$$

16.2 *Bias*—The procedure in this test method has no bias because lubricity is not a fundamental and measurable fluid property and thus is evaluated in terms of this test method.

17. Keywords

17.1 boundary lubrication; diesel fuel; friction; lubricity; wear

²¹ Supporting data are available from ASTM Headquarters. Request RR:D02-1411.

(Mandatory Information)
A1. SURFACE FINISHING PROCEDURE FOR TEST RINGS
A1.1 Summary of Procedure

A1.1.1 Accurate control of the surface finish on the cylindrical test specimens is central to the accuracy of the SLB-OCLE test procedure. Optimum repeatability and reproducibility between laboratories will be obtained if the specimens are procured from the source detailed in Footnote 22.

A1.1.2 Test specimens are first ground and then polished using diamond paste compound to achieve the required surface texture. The surface of the test specimens should be polished to a mirror finish with a slight waviness visible to the naked eye.

A1.1.3 Excessively smooth or rough surfaces have been found to decrease the scuffing load result obtained for the test fuel.

A1.2 Reagents and Materials

A1.2.1 *Unfinished Test Rings*, of SAE 8720 steel, having a Rockwell hardness “C” scale (HRC) number of 58 to 62 and a surface finish of 0.56 to 0.71- μm root mean square.^{12,22}

A1.2.2 *Grinding Wheel*, medium (60 grit) aluminum oxide wheel with vitrified bond of medium hardness.^{12,23}

A1.2.3 *Lathe*, 15-in. with quick carriage reverse.^{12,24}

A1.2.4 *Grinder*, tool post grinder suitable for use with 15-in. lathe described in A1.2.3.^{12,25}

A1.2.5 *Polishing Compound*, 6- μm diamond polishing paste.^{12,26}

A1.2.6 *Polishing Pads*, 8-in. diameter circular adhesive-backed polishing cloth.^{12, 27}

A1.2.7 *Polishing Disk*, custom-made 8-in. diameter aluminum disk to hold polishing pads, suitable for use with grinder described in A1.2.4.

A1.2.8 *Mandrel*, custom-made mandrel to hold test rings during grinding and polishing procedures. The mandrel is similar in form to that shown in Fig. 2 but of more robust construction to minimize deflection during machining.

A1.3 Preparation for Grinding

A1.3.1 Load the mandrel in the adjustable lathe chuck.

A1.3.2 Adjust the chuck until the tapered surface of the mandrel runs true within 0.0005 in.

A1.3.3 Mount the grinder with the spindle parallel to lathe centerline.

A1.3.4 Adjust the grinder to operate at 4700 r/min.

A1.3.5 Set the lathe carriage stop to prevent damage to the lathe or grinder.

A1.3.6 Mount the grinding wheel and dress with single-point diamond for fine grinding.

A1.3.7 Set the lathe spindle speed to 80 r/min. and carriage feed at 0.055 in./revolution.

A1.3.8 Redress the wheel, when required, or after every 25 test rings.

A1.4 Grinding Procedure

A1.4.1 Clean the tapered surface of the mandrel.

A1.4.2 Place the unfinished ring on the mandrel and secure.

A1.4.3 Run the lathe in reverse, that is, in the opposite direction to the grinder.

A1.4.4 Lightly touch the grinding wheel to unfinished ring.

A1.4.5 Traverse the grinding wheel across unfinished ring.

A1.4.6 Reverse carriage travel.

A1.4.7 Feed the wheel into unfinished ring in 0.0005-in. increments until the ring is ground over the entire circumference.

A1.4.8 Make two passes across the ring with no increase in depth of cut.

A1.4.9 Move the grinder clear of ring.

A1.4.10 Stop the lathe spindle.

A1.4.11 Remove the ring.

A1.4.12 Repeat from A1.4.1 with the next unfinished ring, as necessary.

A1.5 Preparation for Polishing

A1.5.1 Clean the tapered surface of the mandrel.

A1.5.2 Verify the tapered surface of the mandrel runs true within 0.0005 in.

A1.5.3 Install the grinder with spindle 90° to lathe centerline.

A1.5.4 Install 8-in. polishing disc and adjust until parallel to lathe centerline within 0.001 in.

A1.5.5 Set the lathe carriage stop so that the mandrel travels to approximately ¼ in. from washer and mounting bolt at center of polishing disc.

A1.5.6 Remove the polishing disc.

A1.5.7 Install safety cover on grinder.

A1.5.8 Install polishing pad on polishing disc.

A1.5.9 Evenly spread ¼ tube of polishing compound over polishing disc.

A1.5.10 Set the lathe speed at 625 r/min. and feed at 0.011 in. per revolution.

A1.5.11 Mount the ground ring on mandrel.

A1.5.12 Run the lathe in opposite direction to grinder.

A1.5.13 Lightly touch rotating polishing disk and pad to ground ring and traverse across ring one time in both directions to distribute compound over discs.

²² Test rings (Part No. F25061 from Falex Corp., 1020 Airpark Dr., Sugar Grove, IL 60554-9585) have been found satisfactory.

²³ Part No. 57A60-K5VBE of size 5 in. by 3/8 in. by 1/2 in., manufactured by Norton Grinding Wheels, Worcester, MA 01606, has been found satisfactory.

²⁴ Republic Engine Lathe, 15 in. by 60 in., manufactured by Republic-Lagun Machine Tool, 1000 East Carson St., Carson, CA 90749, has been found satisfactory.

²⁵ Themac Tool Post Grinder Type J45 manufactured by Themac, Inc., P.O. Box 444, East Rutherford, NJ 07073 has been found satisfactory.

²⁶ Hyprez 6 (OS) 375-NAT, manufactured by Engis Corp., 105 West Hintz Road, Wheeling, IL 60090, has been found satisfactory.

²⁷ Part Number 40-7210 micro cloth pads manufactured by Buehler Ltd., 41 Waukegan Rd. Lake Bluff, IL 60044 have been satisfactory.

A1.5.14 Reverse the carriage direction. Infeed tool grinder by 0.002 in.

A1.6 Polishing Procedure

A1.6.1 Traverse the polishing pad six times across ground ring, that is, three traverses in each direction or until the required surface finish is obtained.

A1.6.2 Increase the pressure on the polishing pad on ring, as required by infeeding tool post grinder, in increments of 0.002 in.

A1.6.3 Repeat from A1.6.1 for subsequent rings.

A1.6.4 Add 1.8 g of polishing compound to the polishing pad every fifth ring.

A1.6.5 Replace the polishing pad as required, or after 25 rings. Repeat procedure from A1.5.7.

A1.7 Required Finish

A1.7.1 The finished test rings should have a center line average (CLA) surface roughness of between 0.04 and 0.15 μm when the measured profile is filtered to consider the effects of wavelengths below 2.5 mm over a total profile length of 7.5 mm.

ASTM International takes no position respecting the validity of any patent rights asserted in connection with any item mentioned in this standard. Users of this standard are expressly advised that determination of the validity of any such patent rights, and the risk of infringement of such rights, are entirely their own responsibility.

This standard is subject to revision at any time by the responsible technical committee and must be reviewed every five years and if not revised, either reapproved or withdrawn. Your comments are invited either for revision of this standard or for additional standards and should be addressed to ASTM International Headquarters. Your comments will receive careful consideration at a meeting of the responsible technical committee, which you may attend. If you feel that your comments have not received a fair hearing you should make your views known to the ASTM Committee on Standards, at the address shown below.

This standard is copyrighted by ASTM International, 100 Barr Harbor Drive, PO Box C700, West Conshohocken, PA 19428-2959, United States. Individual reprints (single or multiple copies) of this standard may be obtained by contacting ASTM at the above address or at 610-832-9585 (phone), 610-832-9555 (fax), or service@astm.org (e-mail); or through the ASTM website (www.astm.org).