



Standard Test Methods for Pitting and Crevice Corrosion Resistance of Stainless Steels and Related Alloys by Use of Ferric Chloride Solution¹

This standard is issued under the fixed designation G 48; the number immediately following the designation indicates the year of original adoption or, in the case of revision, the year of last revision. A number in parentheses indicates the year of last reappraisal. A superscript epsilon (ϵ) indicates an editorial change since the last revision or reappraisal.

1. Scope

1.1 These test methods cover procedures for the determination of the resistance of stainless steels and related alloys to pitting and crevice corrosion (see Terminology G 15) when exposed to oxidizing chloride environments. Six procedures are described and identified as Methods A, B, C, D, E, and F.

1.1.1 *Method A*—Ferric chloride pitting test.

1.1.2 *Method B*—Ferric chloride crevice test.

1.1.3 *Method C*—Critical pitting temperature test for nickel-base and chromium-bearing alloys.

1.1.4 *Method D*—Critical crevice temperature test for nickel-base and chromium-bearing alloys.

1.1.5 *Method E*—Critical pitting temperature test for stainless steels.

1.1.6 *Method F*—Critical crevice temperature test for stainless steels.

1.2 Method A is designed to determine the relative pitting resistance of stainless steels and nickel-base, chromium-bearing alloys, whereas Method B can be used for determining both the pitting and crevice corrosion resistance of these alloys. Methods C, D, E and F allow for a ranking of alloys by minimum (critical) temperature to cause initiation of pitting corrosion and crevice corrosion, respectively, of stainless steels, nickel-base and chromium-bearing alloys in a standard ferric chloride solution.

1.3 These tests may be used to determine the effects of alloying additives, heat treatment, and surface finishes on pitting and crevice corrosion resistance.

1.4 The values stated in SI units are to be regarded as the standard. Other units are given in parentheses for information only.

1.5 *This standard does not purport to address all of the safety concerns, if any, associated with its use. It is the responsibility of the user of this standard to establish appropriate*

safety and health practices and determine the applicability of regulatory limitations prior to use.

2. Referenced Documents

2.1 ASTM Standards:

A 262 Practices for Detecting Susceptibility to Intergranular Attack in Austenitic Stainless Steels²

D 1193 Specification for Reagent Water³

E 691 Practice for Conducting an Interlaboratory Study to Determine the Precision of a Test Method⁴

E 1338 Guide for the Identification of Metals and Alloys in Computerized Material Property Databases⁵

G 1 Practice for Preparing, Cleaning, and Evaluating Corrosion Test Specimens⁶

G 15 Terminology Relating to Corrosion and Corrosion Testing⁶

G 46 Guide for Examination and Evaluation of Pitting Corrosion⁶

G 107 Guide for Formats for Collection and Compilation of Corrosion Data for Metals for Computerized Database Input⁶

3. Terminology

3.1 Definition of Terms Specific to This Standard:

3.1.1 *critical crevice temperature, n*—the minimum temperature ($^{\circ}\text{C}$) to produce crevice attack at least 0.025-mm (0.001-in.) deep on the bold surface of the specimen beneath the crevice washer, edge attack ignored.

3.1.2 *critical pitting temperature, n*—the minimum temperature ($^{\circ}\text{C}$) to produce pitting attack at least 0.025-mm (0.001-in.) deep on the bold surface of the specimen, edge attack ignored.

3.2 The terminology used herein, if not specifically defined otherwise, shall be in accordance with Terminology G 15.

¹ These test methods are under the jurisdiction of ASTM Committee G01 on Corrosion of Metals, and are the direct responsibility of Subcommittee G01.05 on Laboratory Corrosion Tests.

Current edition approved May 10, 2003. Published July 2003. Originally approved in 1976. Last previous edition approved in 2000 as G 48 – 00.

² *Annual Book of ASTM Standards*, Vol 01.03.

³ *Annual Book of ASTM Standards*, Vol 11.01.

⁴ *Annual Book of ASTM Standards*, Vol 14.02.

⁵ *Annual Book of ASTM Standards*, Vol 02.05.

⁶ *Annual Book of ASTM Standards*, Vol 03.02.

Definitions provided herein and not given in Terminology G 15 are limited only to this standard.

4. Significance and Use

4.1 These test methods describe laboratory tests for comparing the resistance of stainless steels and related alloys to the initiation of pitting and crevice corrosion. The results may be used for ranking alloys in order of increasing resistance to pitting and crevice corrosion initiation under the specific conditions of these methods. Methods A and B are designed to cause the breakdown of Type 304 at room temperature.

4.2 The use of ferric chloride solutions is justified because it is related to, but not the same as, that within a pit or crevice site on a ferrous alloy in chloride bearing environments (1, 2).⁷ The presence of an inert crevice former of consistent dimension on a surface is regarded as sufficient specification of crevice geometry to assess relative crevice corrosion susceptibility.

4.3 The relative performance of alloys in ferric chloride solution tests has been correlated to performance in certain real environments, such as natural seawater at ambient temperature (3) and strongly oxidizing, low pH, chloride containing environments (4), but several exceptions have been reported (4-7).

4.4 Methods A, B, C, D, E, and F can be used to rank the relative resistance of stainless steels and nickel base alloys to pitting and crevice corrosion in chloride-containing environments. No statement can be made about resistance of alloys in environments that do not contain chlorides.

4.4.1 Methods A, B, C, D, E, and F were designed to accelerate the time to initiate localized corrosion relative to most natural environments. Consequently, the degree of corrosion damage that occurs during testing will generally be greater than that in natural environments in any similar time period.

4.4.2 No statement regarding localized corrosion propagation can be made based on the results of Methods A, B, C, D, E or F.

4.4.3 Surface preparation can significantly influence results. Therefore, grinding and pickling of the specimen will mean that the results may not be representative of the conditions of the actual piece from which the sample was taken.

NOTE 1—Grinding or pickling on stainless steel surfaces may destroy the passive layer. A 24-h air passivation after grinding or pickling is sufficient to minimize these differences (8).

4.4.4 The procedures in Methods C, D, E and F for measuring critical pitting corrosion temperature and critical crevice corrosion temperature have no bias because the values are defined only in terms of these test methods.

5. Apparatus

5.1 *Glassware*—Methods A, B, C, D, E, and F provide an option to use either wide mouth flasks or suitable sized test tubes. Condensers are required for elevated temperature testing when solution evaporation may occur. Glass cradles or hooks also may be required.

5.1.1 *Flask Requirements*, 1000-mL wide mouth. Tall form or Erlenmeyer flasks can be used. The mouth of the flask shall

have a diameter of about 40 mm (1.6 in.) to allow passage of the test specimen and the support.

5.1.2 *Test Tube Requirements*, the diameter of the test tube shall also be about 40 mm (1.6 in.) in diameter. If testing requires use of a condenser (described below), the test tube length shall be about 300 mm (about 12 in.); otherwise, the length can be about 150 to 200 mm (about 6 in. to 8 in.).

5.1.3 *Condensers, Vents and Covers*:

5.1.3.1 A variety of condensers may be used in conjunction with the flasks described in 5.1.1. These include the cold finger-type (see, for example, Practices A 262, Practice C) or Allihn type condensers having straight tube ends or tapered ground joints. Straight end condensers can be inserted through a bored rubber stopper. Likewise, a simple U tube condenser can be fashioned.

NOTE 2—The use of ground joint condensers requires that the mouth of the flask have a corresponding joint.

5.1.3.2 *U Tube Condensers*, fitted through holes in an appropriate size rubber stopper can be used in conjunction with the 300-mm test tube described in 5.1.2.

5.1.3.3 When evaporation is not a significant problem, flasks can be covered with a watch glass. Also, flasks as well as test tubes can be covered with loosely fitted stoppers or plastic or paraffin type wraps.

NOTE 3—Venting must always be considered due to the possible build up of gas pressure that may result from the corrosion process.

5.1.4 *Specimen Supports*:

5.1.4.1 One advantage of using test tubes is that specimen supports are not required. However, placement of the specimen does create the possible opportunity for crevice corrosion to occur along the edge.

NOTE 4—See 14.2 concerning edge attack.

5.1.4.2 When using flasks, specimens can be supported on cradles or hooks. Cradles, such as those shown in Fig. 1, eliminate the necessity for drilling a support hole in the test specimen. While the use of hooks requires that a specimen support hole be provided, the hooks, as contrasted to the cradle, are easier to fashion. Moreover, they create only one potential crevice site whereas multiple sites are possible with the cradle.

NOTE 5—A TFE-fluorocarbon cradle may be substituted for glass.

5.1.4.3 The use of supports for Methods B, D, and F crevice corrosion specimens is optional.

5.2 *Water or Oil Bath*, constant temperature.

5.2.1 For Methods A and B, the recommended test temperatures are $22 \pm 2^\circ\text{C}$ or $50 \pm 2^\circ\text{C}$, or both.

5.2.2 For Methods C, D, E, and F, the bath shall have the capability of providing constant temperature between 0°C and $85^\circ\text{C} \pm 1^\circ\text{C}$.

5.3 *Crevice Formers—Method B*:

5.3.1 *Cylindrical TFE-fluorocarbon Blocks*, two for each test specimen. Each block shall be 12.7-mm (0.5 in.) in diameter and 12.7-mm high, with perpendicular grooves 1.6-mm (0.063 in.) wide and 1.6-mm deep cut in the top of each cylinder for retention of the O-ring or rubber bands. Blocks can be machined from bar or rod stock.

⁷ The boldface numbers in parentheses refer to the list of references at the end of this standard.

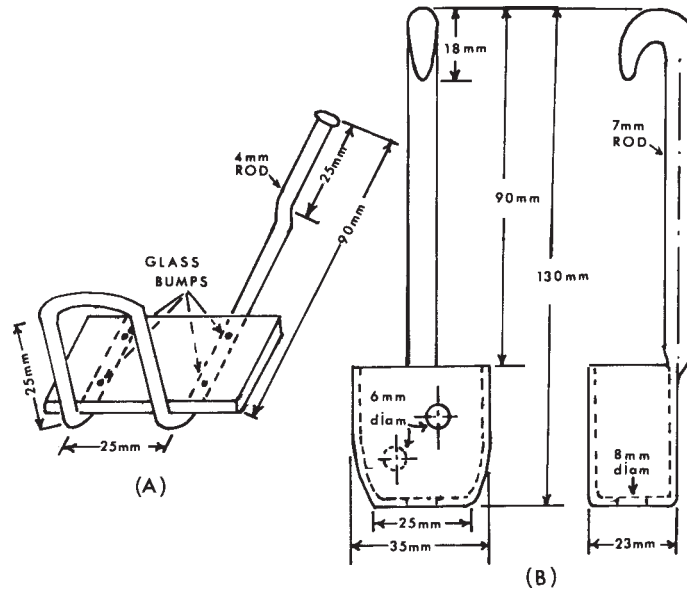

FIG. 1 Examples of Glass Cradles that Can Be Used to Support the Specimen

5.3.2 Fluorinated Elastomers O-rings, or Rubber Bands, (low sulfur (0.02 % max)), two for each test specimen.

NOTE 6—It is good practice to use all O-rings or all rubber bands in a given test program.

5.3.2.1 O-rings shall be 1.75 mm (0.070 in.) in cross section; one ring with an inside diameter of about 20 mm (0.8 in.) and one with an inside diameter of about 30 mm (1.1 in.). Rubber bands shall be one No. 12 (38-mm (1.5-in.) long) and one No. 14 (51-mm (2-in.) long).

NOTE 7—Rubber bands or O-rings can be boiled in water prior to use to ensure the removal of water-soluble ingredients that might affect corrosion.

5.4 Crevice Formers—Methods D and F:

5.4.1 A Multiple Crevice Assembly (MCA), consisting of two TFE-fluorocarbon segmented washers, each having a number of grooves and plateaus, shall be used. The crevice design shown in Fig. 2 is one of a number of variations of the

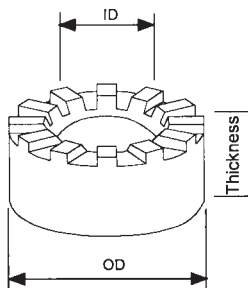

Type	ID		OD		Thickness		Number of Slots
	mm	in	mm	in	mm	in	
A	6.73	0.265	15.9	0.625	2.54	0.100	12
B	6.73	0.265	15.9	0.625	6.34	0.250	12
C	9.92	0.391	15.9	0.625	6.34	0.250	12

FIG. 2 TFE-fluorocarbon Crevice Washers

multiple crevice assembly that is in use and commercially available.⁸

5.4.2 Reuse of Multiple Crevice Assemblies, when assembled to the specified torque, the TFE-fluorocarbon segmented washers should not deform during testing. Before reuse, each washer should be inspected for evidence of distortion and other damage. If so affected, they should be discarded. In some cases, the crevice formers may become stained with corrosion products from the tested alloy. Generally, this staining can be removed by immersion in dilute HCl (for example, 5-10% by volume) at room temperature, followed by brushing with mild detergent and through rinsing with water.

5.4.3 Fasteners, one alloy UNS N10276 (or similarly resistant alloy) fastener is required for each assembly. Each assembly comprises a threaded bolt and nut plus two washers. The bolt length shall be sized to allow passage through the mouth of the glassware described in 5.1.

5.5 Tools and Instruments:

5.5.1 A 6.35-mm (1/4-in.) torque limiting nut driver is required for assembly of the Methods D and F crevice test specimen.

5.5.2 Low Power Microscope, (for example, 20× magnification) for pit detection.

5.5.3 Needle Point Dial Depth Indicator or Focusing Microscope, to determine the depth of pitting or crevice corrosion, or both.

5.5.4 Electronic Balance (optional), to determine specimen mass to the nearest 0.0001 g.

5.5.5 Camera (optional), to photographically record the mode and extent of any localized corrosion.

⁸ The sole source of supply of the apparatus known to the committee at this time is Metal Samples Co., Inc., P.O. Box 8, Route 1 Box 152, Munford, AL 36268. If you are aware of alternative suppliers, please provide this information to ASTM Headquarters. Your comments will receive careful consideration at a meeting of the responsible technical committee,¹ which you may attend.

6. Ferric Chloride Test Solution

6.1 For Methods A and B, dissolve 100 g of reagent grade ferric chloride, $\text{FeCl}_3 \cdot 6\text{H}_2\text{O}$, in 900 mL of Type IV reagent water (Specification D 1193) (about 6 % FeCl_3 by mass). Filter through glass wool or filter paper to remove insoluble particles if present.

6.2 For Methods C, D, E, and F, dissolve 68.72 g of reagent grade ferric chloride, $\text{FeCl}_3 \cdot 6\text{H}_2\text{O}$ in 600 mL of reagent water and add 16 mL of reagent grade concentrated (36.5–38.0 %) hydrochloric acid (HCl). This will produce a solution containing about 6 % FeCl by mass and 1 % HCl resulting in a pH controlled environment over the test temperatures (9).

7. Test Specimens

7.1 A test specimen 25 by 50 mm (1 by 2 in.) is recommended as a standard size, although various shapes and sizes can be tested by this method. All specimens in a test series should have the same dimensions when comparisons are to be made. Unless end-grain pitting is an integral part of the evaluation, the proportion of end-grain surface to specimen surface should be kept as small as possible given the limitations of specimen sizes because of the susceptibility of end-grain surfaces to pitting.

NOTE 8—The thickness of the specimen in Method B can influence the tightness of the crevice and the test results.

NOTE 9—End-grain attack in Methods C, D, E, and F may not be as prevalent in a test in which low test temperatures are anticipated.

7.2 When specimens are cut by shearing, the deformed material should be removed by machining or grinding prior to testing unless the corrosion resistance of the sheared edges is being evaluated. It is good practice to remove deformed edges to the thickness of the material.

7.3 For Methods D and F, a sufficient hole should be drilled and chamfered in the center of the specimen to accommodate the bolt and insulating sleeve used to attach the crevice device.

7.4 All surfaces of the specimen should be polished to a uniform finish. A120-grit abrasive paper has been found to provide a satisfactory standard finish. Wet polishing is preferred, but if dry polishing is used, it should be done slowly to avoid overheating. The sharp edges of a specimen should be rounded to avoid cutting rubber bands or O-rings.

NOTE 10—While a polished surface is preferred for uniformity, the test may be varied at the discretion of the investigator to evaluate other surface finishes, such as a mill finish.

7.5 Measure the dimensions of the specimen, and calculate the total exposed area of interest.

7.6 Clean specimen surfaces with magnesium oxide paste or equivalent, rinse well with water, dip in acetone or methanol, and air-dry.

7.7 Weigh each specimen to the nearest 0.001 g or better and store in a desiccator until ready for use (see Practice G 1).

8. Method A—Ferric Chloride Pitting Test

8.1 Procedure:

8.1.1 Pour 600 mL of the ferric chloride test solution into the 1000-mL test beaker. If specimens larger than the standard are used, provide a solution volume of at least 5 mL/cm^2 (30 mL/in.^2) of specimen surface area. Transfer the test beaker to

a constant temperature bath and allow the test solution to come to the equilibrium temperature of interest. Recommended temperatures for evaluation are $22 \pm 2^\circ\text{C}$ and $50 \pm 2^\circ\text{C}$.

8.1.2 Place the specimen in a glass cradle and immerse in the test solution after it has reached the desired temperature. Maintain test solution temperature throughout the test.

8.1.3 Cover the test vessel with a watch glass. A reasonable test period is 72 h, although variations may be used at the discretion of the investigator and depend on the materials being evaluated.

8.1.4 Remove the specimens, rinse with water and scrub with a nylon bristle brush under running water to remove corrosion products, dip in acetone or methanol, and air-dry. Ultrasonic cleaning may be used as a substitute method in cases in which it is difficult to remove corrosion products from deep pits.

8.1.5 Weigh each specimen to 0.001 g or better and reserve for examination (see Practice G 1).

9. Method B—Ferric Chloride Crevice Corrosion Test (10)

9.1 Procedure:

9.1.1 Add 150 mL of ferric chloride solution to each test tube, insert a rubber stopper, and place the tube in a thermostated bath until it comes to the equilibrium temperature of interest. Recommended temperatures for evaluation are $22 \pm 2^\circ\text{C}$ and $50 \pm 2^\circ\text{C}$.

9.1.2 Fasten two TFE-fluorocarbon blocks to the test specimen with O-rings or a double loop of each of two rubber bands as shown in Fig. 3. Use plastic gloves to avoid hand contact with metal surfaces during this operation. Use the small O-ring or the No. 12 rubber band for the 25-mm (1-in.) dimension and the large O-ring or the No. 14 rubber band for the 50-mm (2-in.) dimension.

9.1.3 After the test solution has reached the desired temperature, tilt the tube at a 45° angle and slide the test specimen to the bottom of the tube, replace the stopper, and return the tube to the bath.

9.1.4 A reasonable test period is 72 h, although variations may be used at the discretion of the investigator and depend on the materials being evaluated. Specimens may be inspected at intervals by decanting the test solution into a clean beaker and

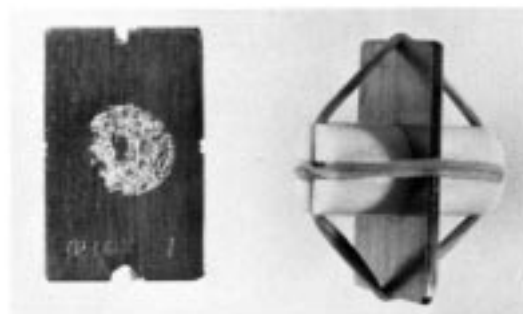

(a) Specimen After Test with Attack at Four Crevices Under Rubber Bands and Under One Block
(b) Assembled Crevice Test Specimen

FIG. 3 Ferric Chloride Crevice Test Specimen

sliding the specimen from the test tube. Rinse the specimen in water and examine under the four points of contact for the O-rings or rubber bands and under both TFE-fluorocarbon blocks. If further exposure is required, the specimen and solution should be returned to the test tube before the specimen dries and the test tube should be immediately returned to the bath.

NOTE 11—The removal of specimens for inspection may affect the rate of corrosion, and caution should be observed when comparing these results with those obtained from constant immersion tests.

9.1.5 After the test has been completed, remove the test specimens, rinse with water, and scrub with a nylon bristle brush under running water to remove corrosion products, dip in acetone or methanol, and air-dry. Ultrasonic cleaning may be used in those cases in which it is difficult to remove corrosion products from deep pits or crevices.

9.1.6 Weigh each specimen to the nearest 0.001 g or better and reserve for examination.

10. Method C—Critical Pitting Temperature Test for Nickel-Base and Chromium-Bearing Alloys:

NOTE 12—See Table 1.

10.1 Procedure:

10.1.1 Pour 600 mL of acidified ferric chloride test solution into the test container. If specimens larger than the standard are used, provide a solution volume of at least 5 mL/cm²(30 mL/in.²) of surface area. Cover the container with a watch glass, transfer to a constant temperature bath, and allow to come to the equilibrium temperature of interest. Verify the temperature before starting the test.

10.1.2 If test tubes are used instead of a 1000-mL test container, 150 mL of test solution shall be added.

10.1.3 Place the specimen in a glass cradle and immerse in the test solution after it has reached the desired temperature. The starting temperature may be estimated by the following equation (11, 12).

$$CPT (°C) = (2.5 \times \% Cr) + (7.6 \times \% Mo) + (31.9 \times \% N) - 41.0 \quad (1)$$

Testing shall begin at the nearest increment of 5°C, estimated by the above equation. The minimum temperature of test is 0°C and the maximum temperature of test is 85°C. No more than one specimen shall be placed in a test container. Replace the watch glass on the container. Maintain the temperature (±1°C (±1.8°F)) throughout the test period. The standard test period is 72 h. This test period was evaluated by interlaboratory

testing, 16.1.2, and is required to produce attack on some highly corrosion resistant nickel-based alloys. The test period must be reported as indicated in 15.1.

NOTE 13—Critical pitting or crevice testing is likely to require three to five replicate samples to determine the critical temperature for each alloy/condition.

NOTE 14—While testing may be done at a higher temperature, 85°C was the maximum temperature of the test in the round robin.

10.1.4 At the end of the test period, remove the specimen, rinse with water, scrub with a nylon bristle brush under running water to remove corrosion products, dip in acetone or methanol, and dry.

10.1.5 Inspection is done in accordance with Section 14. Pitting corrosion is considered to be present if the local attack is 0.025 mm (0.001 in.) or greater in depth.

10.1.5.1 If minimum or greater pitting attack is observed, lower the bath temperature 5°C, and using a new specimen and fresh solution, repeat steps 10.1.1 to 10.1.5, or

10.1.5.2 If less than minimum pitting attack is observed, raise the bath temperature 10°C, and using a new specimen and fresh solution, repeat steps 10.1.1-10.1.5.

11. Method D—Critical Crevice Temperature Test for Nickel-Based and Chromium-Bearing Alloys (13) :

NOTE 15—See Table 1.

11.1 Procedure:

11.1.1 Apply the two crevice washers to the specimen. A TFE-fluorocarbon tubular sleeve (for electrical isolation), and a bolt, a nut, and flat washers of UNS N10276 may be used to fasten the crevice washers to the specimen, as illustrated in Fig. 4. Insulating sleeves shall be used around the bolt and the specimen shall be checked for electrical contact with the bolt. The torque on the bolt influences the tightness of the crevice and the test results. A torque of 0.28 Nm (40 in.-oz) shall be applied using a 6.35-mm (¼-in.) drive torque limiting nut-driver. The torque must be reported as indicated in 15.1.

NOTE 16—The torque of 0.28 Nm (40 in.-oz) was evaluated by inter-laboratory testing, 16.1.2.

NOTE 17—(a) Titanium bolts, nuts, and flat washers may also be used to attach the crevice washers to the specimen. (b) Different crevice devices may give different results for the same torque.

11.1.2 Pour 600 mL of acidified ferric chloride test solution into the 1000-mL test container. Cover the container with a watch glass, transfer to a constant temperature bath, and allow to come to equilibrium temperature of interest. Verify the temperature before starting the test.

TABLE 1 Results of First Interlaboratory Test Program

NOTE 1—Minimum temperature (°C) to produce attack at least 0.025-mm (0.001-in.) deep on bold surface of specimen. Edge attack ignored.

Alloy/Laboratory	Method C—CPT Critical Pitting Corrosion Temperature (C)				Method D—CCT Critical Crevice Corrosion Temperature (C)			
	UNS S31603	UNS N08367	UNS S44735	UNS N06022	UNS S31603	UNS N08367	UNS S44735	UNS N06022
1	20/20/20	75/ ^A /75	85/85/85	>85/>85/>85	<0/<0/<0	30/30/30	42/35/42	50/ ^A /50
2	20/20/20	70/70/70	80/80/80	>85/>85/>85	<0/<0/<0	25/25/25	35/35/ ^A	50/55/55
3	20/20/20	85/85/85	75/85/85	>85/>85/>85	<0/<0/<0	25/30/30	35/40/40	55/60/60
4	19/19	75/80	81/81	>85/>85	<0/<0	34/34	40/40	67/67
5	20/20/20	75/75/75	70/70/75	>85/>85/>85	<0/<0/<0	20/20/20	45/45/45	
6	20/20	75/80	75/85	>85/>85	<0/<0	30/30	40/40	55/55

^ATest run but no attack observed.

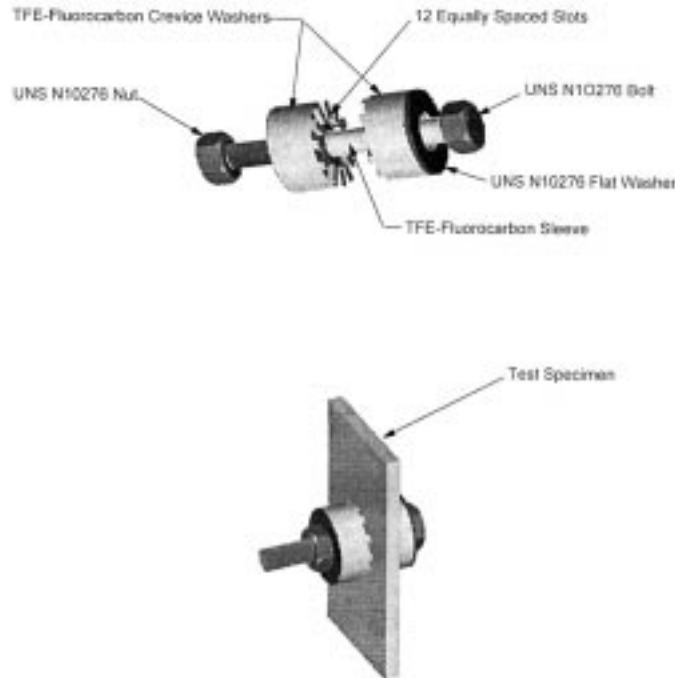

FIG. 4 Method D and F Crevice Assembly

11.1.3 If test tubes are used instead of a 1000-mL test container, 150 mL of test solution shall be added.

11.1.4 Immerse the specimen in the test solution after it has reached the desired temperature. The starting temperature may be estimated for nickel base alloys by the following equation (14):

$$CCT (^{\circ}C) = (1.5 \times \% Cr) + (1.9 \times \% Mo) + (4.9 \times \% Nb) + (8.6 \times \% W) - 36.2 \quad (2)$$

Testing shall begin at the nearest increment of 5°C, estimated by the above equations. The minimum temperature of test is 0°C and the maximum temperature of test is 85°C (see Note 15). No more than one specimen shall be placed in a test container. Replace the watch glass on the container and maintain the temperature ($\pm 1^{\circ}C$ ($\pm 1.8^{\circ}F$)) throughout the test period. The standard test period is 72 h. This test period was evaluated by interlaboratory testing, 16.1.2, and is required to produce attack on some highly corrosion resistant nickel-based alloys. (13, 14) The test period must be reported as indicated in 15.1.

11.1.5 At the end of the test period, remove the specimen, rinse with water, and scrub with a nylon bristle brush under running water to remove corrosion products, dip in acetone or methanol, and dry.

11.1.6 Inspection is done in accordance with Section 14. Crevice corrosion is considered to be present if the local attack is 0.025 mm (0.001 in.) or greater in depth.

11.1.6.1 If minimum or greater crevice corrosion attack is observed, lower the bath temperature 5°C, and using a new specimen and fresh solution, repeat steps 11.1.1-11.1.6, or

11.1.6.2 If less than minimum crevice corrosion attack is observed, raise the bath temperature 10°C, and using a new specimen and fresh solution, repeat steps 11.1.1-11.1.6.

12. Method E-Critical Pitting Temperature Test for Stainless Steels

NOTE 18—See Table 2.

12.1 Procedure:

12.1.1 Pour 600 mL of acidified ferric chloride test solution into the test container. If specimens larger than the standard are

TABLE 2 Results of Second Interlaboratory Test Program

NOTE 1—Minimum temperature (°C) to produce attack at least 0.025-mm (0.001-in.) deep on bold surface of specimen. Edge attack ignored.

Alloy/Laboratory	Method E—CPT Critical Pitting Corrosion Temperature (C)				Method F—CCT Critical Crevice Corrosion Temperature (C)			
	UNS S31603	UNS S31803	UNS S44735	UNS N08367	UNS S31603	UNS S31803	UNS S44735	UNS N08367
1	15/15/ ^A	30/30/30	85/85/85	75/ ^A	0/0/0	15/ ^A / ^A	30/ ^A / ^A	30/30/30
2	10/ ^A / ^A	25/25/ ^A	80/80/80	75/75	0/0/0	15/15/15	30/30/30	25/25/25
3	0/0/0	25/25/ ^A	80/80/80	70/70/ ^A	0/0/0	20/20/20	35/35/35	30/30/ ^A
4	15/15/ ^A	30/30/30	75/ ^A / ^A	75/75/ ^A	0/0/0	20/20/20	20/20/20	20/20/20
5	15/15/15	20/ ^A	80/80/80	70/70/70	0/0/0	20/20/20	35/35/35	30/30/30
6		40		75		15	35	25
7	15/15/15	35/35/35	>85/>85/>85	75/75/75	0/0/0	25/25/25	35/ ^A / ^A	30/30/30

^ATest run but no attack observed.

used, provide a solution volume of at least 5 mL/cm² (30 mL/in.²) of surface area. Cover the container with a watch glass, transfer to a constant temperature bath, and allow to come to the equilibrium temperature of interest. Verify the temperature before starting the test.

12.1.2 If test tubes are used instead of a 1000-mL test container, 150 mL of test solution shall be added.

12.1.3 Place the specimen in a glass cradle and immerse in the test solution after it has reached the desired temperature. The starting temperature may be estimated by the following Eq. 1 of 10.1.3.

Testing shall begin at the nearest increment of 5°C, estimated by the above equation. The minimum temperature of test is 0°C and the maximum temperature of test is 85°C. See Notes 13 and 14 of 10.1.3. No more than one specimen shall be placed in a test container. Replace the watch glass on the container. Maintain the temperature ($\pm 1^\circ\text{C}$ ($\pm 1.8^\circ\text{F}$)) throughout the test period. The standard test period is 24 h. This test period was evaluated by interlaboratory testing, 16.1.2. The test period must be reported as indicated in 15.1.

12.1.4 At the end of the test period, remove the specimen, rinse with water, scrub with a nylon bristle brush under running water to remove corrosion products, dip in acetone or methanol, and dry.

12.1.5 Inspection is done in accordance with Section 14. Pitting corrosion is considered to be present if the local attack is 0.025 mm (0.001 in.) or greater in depth.

12.1.5.1 If minimum or greater pitting attack is observed, lower the bath temperature 5°C, and using a new specimen and fresh solution, repeat steps 12.1.1-12.1.5, or

12.1.5.2 If less than minimum pitting attack is observed, raise the bath temperature 10°C, and using a new specimen and fresh solution, repeat steps 12.1.1-12.1.5.

13. Method F-Critical Crevice Temperature Test for stainless steels

NOTE 19—See Table 2.

13.1 Procedure:

13.1.1 Apply the two crevice washers to the specimen. A TFE-fluorocarbon tubular sleeve (for electrical isolation), and a bolt, a nut, and flat washers of UNS N10276 may be used to fasten the crevice washers to the specimen, as illustrated in Fig. 4. Insulating sleeves shall be used around the bolt and the specimen shall be checked for electrical contact with the bolt. The torque on the bolt influences the tightness of the crevice and the test results. A torque of 1.58 Nm (14 in.-lb) shall be applied using a 6.35-mm (1/4-in.) drive torque limiting nut-driver. The torque must be reported as indicated in 15.1.

NOTE 20—The torque of 1.58 Nm (14 in.-lb) was evaluated by interlaboratory testing, 16.1.2.

13.1.2 Pour 600 mL of acidified ferric chloride test solution into the 1000-mL test container. Cover the container with a watch glass, transfer to a constant temperature bath, and allow to come to equilibrium temperature of interest. Verify the temperature before starting the test.

13.1.3 If test tubes are used instead of a 1000-mL test container, 150 mL of test solution shall be added.

13.1.4 Immerse the specimen in the test solution after it has reached the desired temperature. The starting temperature may be estimated for iron base alloys by the following equation (10, 15, 16):

$$\text{CCT } (^\circ\text{C}) = (3.2 \times \% \text{Cr}) + (7.6 \times \% \text{Mo}) + (10.5 \times \% \text{N}) - 81.0 \quad (3)$$

Testing shall begin at the nearest increment of 5°C, estimated by the above equations. The minimum temperature of test is 0°C and the maximum temperature of test is 85°C. See Notes 13 and 14. No more than one specimen shall be placed in a test container. Replace the watch glass on the container and maintain the temperature ($\pm 1^\circ\text{C}$ ($\pm 1.8^\circ\text{F}$)) throughout the test period. The standard test period is 24 h. This test period was evaluated by interlaboratory testing, 16.1.2. The test period must be reported as indicated in 15.1.

13.1.5 At the end of the test period, remove the specimen, rinse with water, and scrub with a nylon bristle brush under running water to remove corrosion products, dip in acetone or methanol, and dry.

13.1.6 Inspection is done in accordance with Section 14. Crevice corrosion is considered to be present if the local attack is 0.025 mm (0.001 in.) or greater in depth.

13.1.6.1 If minimum or greater crevice corrosion attack is observed, lower the bath temperature 5°C, and using a new specimen and fresh solution, repeat steps 13.1.1-13.1.6, or

13.1.6.2 If less than minimum crevice corrosion attack is observed, raise the bath temperature 10°C, and using a new specimen and fresh solution, repeat steps 13.1.1-13.1.6.

14. Examination and Evaluation

14.1 A visual examination and photographic reproduction of specimen surfaces, along with specimen mass losses, are often sufficient to characterize the pitting and crevice resistance of different materials. A more detailed examination will include the measurement of maximum pit depth, average pit depth, pit density, and crevice depth. (See Guide G 46.) A test shall be discarded if a rubber band or O-ring breaks at anytime during the exposure period (Method B).

NOTE 21—Mass loss corrosion rates of greater than or equal to 0.0001 g/cm² may be indicative of pitting or crevice corrosion. Visual examination is required. Photographs of a sample with mass loss less than 0.0001 g/cm² are unnecessary since no sites of attack will be apparent at low magnification.

14.1.1 It is necessary to probe pit sites on the metal surface with a needle to expose subsurface attack. Localized modes of corrosion often result in occluded pits.

14.2 Examine specimen faces for pits at low-magnification (for example, 20× magnification). Distinguish between pits on specimen edges and faces, recognizing that edge pits may affect pitting on specimen faces. Edge pits may be disregarded unless of specific interest; for example, in assessing susceptibility to end-grain attack.

14.3 Measure the deepest pits with an appropriate technique; for example, needle point micrometer gage or microscope with calibrated fine-focus knob or calibrated eyepiece. It may be necessary to probe some pits to ensure exposure of the cavity. Measure a significant number of pits to determine the deepest pit (Methods A, C, and E) and the average of the ten

deepest pits (Method A). Do not include the depth of pits that intersect the edges of the specimen in the calculated average.

14.4 Count the number of pits on the specimen faces under low-power magnification (for example, 20×) to determine pit density (Method A). A clear plastic grid, divided in centimeters, may be helpful, or the surface can be subdivided by scribing with light lines.

14.5 Visually identify crevice attack under O-rings or rubber bands and TFE-fluorocarbon blocks (Method B) or the multiple crevice assembly (Method D and F). Measure the greatest depth of attack at the points of contact of the O-rings or rubber bands (open notch), and under the TFE-fluorocarbon blocks or multiple crevice assembly.

15. Report

15.1 Record the test procedure used, specimen size and surface preparation, time of test, temperature, torque used to fasten the crevice assembly (Method D and F), and the means by which the presence of pits or crevices were assessed for all practices.

NOTE 22—It is important to record the means by which the presence of pits or crevices was assessed since, for example, small diameter pits (or pits in a region of crevice attack) that were not detected by a needle-point micrometer may be observed with a low-magnification microscope. The latter test would, therefore, be considered more severe than the former.

15.2 Record the maximum pit depth (Methods A, C, and E) and the average of the ten deepest pits in micrometers and pit density in pits per square centimeter for both 25 by 50-mm (1 by 2-in.) faces of the specimen (Method A). Record the maximum pit depth on edges if end grain attack is of interest.

15.3 Record the number of attacked sites on each side of the specimen (Methods D and F), the maximum depth of attack (Methods D and F), and the average depth of attack (Method B) in micrometers under the TFE-fluorocarbon blocks and at the point of contact for the O-rings or rubber bands.

15.4 Calculate the specimen mass loss and record in units of grams per square centimeter for Methods A and B.

NOTE 23—The depth and frequency of attack sites provide a more sensitive criterion than mass loss when assessing resistance to pitting and crevice corrosion (Method A and B). For example, little mass would be lost from a specimen that contained only a few small diameter pits that had penetrated the entire specimen cross section. When attack is significant, mass loss per unit of surface area may provide a rapid means of evaluation.

15.5 Refer to Appendix X1 for a recommended standard format for the computerization of pitting and crevice corrosion data in ferric chloride solution as generated by this test method, Methods A, B, C, D, E, and F.

16. Precision and Bias

16.1 *Precision*—Precision is the closeness of agreement between test results obtained under prescribed conditions. In the discussion below, two types of precision are described: repeatability and reproducibility. Repeatability is within laboratory variability when the same operator uses the same

equipment on identical specimens in sequential runs. Reproducibility refers to the variability that occurs when identical specimens are tested under specified conditions at different laboratories.

16.1.1 The precision of Methods A and B for measuring the pitting and crevice corrosion resistance of stainless steels and related alloys using a ferric chloride solution is being determined.

16.1.2 The precision of Methods C and D for measuring critical pitting and crevice corrosion temperatures was determined in an interlaboratory test program with six laboratories running triplicate tests on four materials. The results of these tests are given in Table 1. The precision of Methods E and F for measuring the pitting and crevice corrosion resistance was determined in an interlaboratory test program with seven laboratories running triplicate tests on 4 materials. The results of these tests are given in Table 2 (17). An analysis of the data in the table in accordance with Practice E 691 showed that the results were consistent among laboratories and that there were no significant variations between the materials in either repeatability or reproducibility.

16.1.2.1 The pooled repeatability standard deviation, s_r , and the 95% confidence limits, r , in °C for Methods C, D, E and F for the materials tested were:

Method	s_r	r
C	2	7
D	2	6
E	0	0
F	0	0

16.1.2.2 The pooled reproducibility standard deviation, s_R , and the 95% confidence limits, R , in °C for Methods C, D, E and F for the materials tested were:

Method	s_R	R
C	5	12
D	6	16
E	3	15
F	3	9

NOTE 24—The procedure described above recommends that the temperature be changed in 5°C increments. The analysis procedure given in Practice E 691, however, assumes that the temperature results were continuously variable over the interval. Hence, this analysis produces results in terms of a continuously variable temperature. However, the results may be better interpreted as indicating the repeatability (within laboratory variability) is within one 5°C increment for Methods C and D and there should be no measured difference for Methods E and F. The reproducibility for methods D and E is three 5°C increments, and for Method F it is two or less 5°C increments.

16.2 *Bias*—Because the resistance to pitting and crevice corrosion of stainless steels and related alloys in a ferric chloride solution is defined only in terms of this method, the resistance to pitting and crevice corrosion penetration and the critical pitting and crevice corrosion temperatures have no bias.

17. Keywords

17.1 crevice corrosion; ferric chloride test solution; localized corrosion; nickel–base alloys; pitting; stainless steels

APPENDIX

(Nonmandatory Information)

**X1. RECOMMENDED STANDARD DATA FORMAT FOR COMPUTERIZATION OF DATA FROM
ASTM STANDARD TEST METHOD G48-XX**

X1.1 To encourage uniformity in building computerized corrosion databases and facilitate data comparison and data interchange, it is appropriate to provide recommended standard formats for the inclusion of specific types of test data in such databases. This also has the important effect of encouraging the builders of databases to include sufficiently complete information so that comparisons among individual sources may be made with assurance that the similarities or differences, or both, in the test procedures and conditions are covered therein.

X1.2 Table X1.1 is a recommended standard format for the computerization of pitting and crevice corrosion data in ferric chloride solution as generated by Test Method G 48. There are three columns of information in Table X1.1:

X1.2.1 *Field Number*— A reference number for ease of dealing with the individual fields within this format guideline. It has no permanent value and does not become part of the database itself.—

X1.2.2 *Field Name and Description*—The complete name of the field, descriptive of the element of information that would be included in this field of the database.—

X1.2.3 *Category Sets, Values or Units*—A listing of the types of information that would be included in the field or, in the case of properties or other numeric fields, the units in which the numbers are expressed. Category sets are closed (that is, complete) sets containing all possible (or acceptable) inputs to the field. Values are representative sets, listing sample (but not necessarily all acceptable) inputs to the field.

X1.3 The fields or elements of information included in this format are those recommended to provide sufficiently complete information that users may be confident of their ability to compare sets of data from individual databases and to make the

database useful to a relatively broad range of users.

X1.4 It is recognized that many databases are prepared for very specific applications, and individual database builders may elect to omit certain pieces of information considered to be of no value for that specific application. However, there are a certain minimum number of fields considered essential to any database without which the user will not have sufficient information to reasonably interpret the data. In the recommended standard format, these fields are marked with asterisks.

X1.5 The presentation of this format does not represent a requirement that all of the elements of information included in the recommendation must be included in every database. Rather it is a guide as to those elements that are likely to be useful to at least some users of most databases. It is understood that not all of the elements of information recommended for inclusion will be available for all databases; that fact should not discourage database builders and users from proceeding so long as the minimum basic information is included (the items noted by the asterisks).

X1.6 It is recognized that in some individual cases, additional elements of information of value to users of a database may be available. In those cases, databases builders are encouraged to include them as well as the elements in the recommended format. Guidelines for formats for additional elements are given in Guide G 107.

X1.7 This format is for pitting and crevice corrosion test data only generated by Test Method G 48. It does not include the recommended material descriptors or the presentation of other specific types of test data (such as mechanical property data). These items are covered in Guide E 1338 and by separate formats developed for reporting other material property data.

TABLE X1.1 Recommended Standard Data Format for Computerization of Data from ASTM Standard Test Method G 48-XX

Field No. ^A	Field Name and Description	Category Sets, Values or Units	Field No. ^A	Field Name and Description	Category Sets, Values or Units
Test Identification			Specimen information		
1 ^B	ASTM standard test method	ASTM G-48-XX, Method A, B, C, D, E, or F	25	Specimen identity	alphanumeric string
2	Type of test	Pitting, crevice corrosion	26	No. of duplicate specimens tested	numeric
3	Date test started	yyyymmdd	27	Specimen dimensions—thickness, width/diameter, length	cm, cm, cm
4	Internal laboratory reference number	alphanumeric string	28	Diameter of hole	cm
Test Environment			29	Welded specimen?	Y/N
5 ^B	Percent FeCl ₃ in solution, by weight	%7, %6	30	Weld details	alphanumeric string
6 ^B	Percent HCl in solution, by weight	%1	31	Weld condition	Ground
7 ^B	Capacity of test container	mL			Machined
Exposure Conditions					As deposited
8 ^B	Test temperature	°C ± x°C			Glass bead blasted
9	How was temperature maintained	alphanumeric string	32 ^B	Surface condition	Other
10 ^B	Specimen support	Glass cradle (Method A, C, or E)			As-produced
11 ^B	Type of crevice device	Cylindrical TFE blocks (Method B) Fluorinated elastomer O-ring (Method B) Rubber bands (Method B) TFE washer Type X (Method D or F) Other	33	Surface treatment	Scaled
12 ^B	Torque used, Method D	0.28 Nm Other			Machined/ground
13	Solution volume/specimen surface area	mL/cm ²	34 ^B	Condition of edges	Chemically cleaned
Material Identification ^C					Sand/grit blasted
14	Material class	alphanumeric string	35	Sample orientation relative to working direction	Other
15	Material family	alphanumeric string			None
16	Family subclass	alphanumeric string			Nitrided
17	Common name/trade name	alphanumeric string			Carburized
18 ^B	Unified numbering system designation (UNS No.)	alphanumeric string			Plated
19 ^B	Product shape	Pipe/tube Plate Sheet/strip Wire/rod/bar Other			Clad
20	Product production method	Extrusion Forging Casting Rolling Powder compaction Other	34 ^B	Condition of edges	Anodized
21	Final reduction step	Cold worked (with % education) Hot worked (includes extrusion and forging)			Other
22 ^B	Thermomechanical condition	Standard temper Annealed Normalized Sensitized As cold worked As hot worked Aged Other	35	Sample orientation relative to working direction	As cut
23	Heat/lot identification	alphanumeric string			As sheared
					Ground
					Machined
					Other
					Longitudinal
					Transverse
					Short trasverse
			Specimen Performance		
			36 ^B	Mass loss/unit area	g/cm ²
			37 ^B	Maximum pit depth on planar surfaces	micro-m
			38 ^B	Average pit depth on planar surfaces	micro-m
			39	Pit density	N/cm ²
			40	Maximum pit depth on edges of specimens	micro-m
			41 ^B	Number of attacked sites on each side of the specimen, Methods D and F	(for example) 3 + 5
			42 ^B	Maximum depth of crevice corrosion	micro-m
			43 ^B	Average depth of crevice corrosion	micro-m
			44 ^B	Method used to measure pit and crevice depth	Needle point micrometer Microscope Other
			45 ^B	CPT/CCT temperature determined	°C
			Documentation		
			46	Technical committee report/file	alphanumeric string
			47	Other documentatoin	alphanumeric string

TABLE X1.1 *Continued*

Field No. ^A	Field Name and Description	Category Sets, Values or Units	Field No. ^A	Field Name and Description	Category Sets, Values or Units
24	Heat/lot chemical analysis	alphanumeric string			

^A Field numbers are for reference only. They do not imply a necessity to include all of these fields in any specific database nor imply a requirement that the fields be used in this particular order.

^B Denotes essential information for computerization of test results

^C Refer to Guide E 1338.

REFERENCES

- (1) A. Turnbull, "Solution Composition and Electrode Potential in Pits, Crevices and Cracks," *Corrosion Science*, Vol 23, No. 8, 1983, pp. 833–870.
- (2) B. K. Nash, and R. G. Kelly, "The Use of Ion Chromatography for the Study of Localized Corrosion," Abstract 157, 180th Meeting Electrochemical Society, Phoenix, AZ, Oct. 1991.
- (3) A. Garner, "Crevice Corrosion of Stainless Steels in Seawater: Correlation of Field and Laboratory Tests," *Corrosion*, Vol 37, No. 3, 1981, p. 178.
- (4) J. W. Oldfield, "Test Techniques for Pitting and Crevice Corrosion Resistance of Stainless Steels and Nickel-base Alloys in Chloride-Containing Environments," *International Materials Reviews*, Vol 32, No. 3, 1987, pp. 153–170.
- (5) Tsujikawa, S., et al., "A New Test for Predicting Pitting Corrosion Resistance of CRA's in Sour Environments, Paper No. 64, NACE CORROSION/88 Conference, March 21–25, St. Louis, MO, 1988.
- (6) A. Wensley, C. Reid, D. Brown, and D. Christie, "Corrosion of Stainless Alloys in a Chlorine Dioxide Bleached Pulp Washer," Proceedings 1991 Technical Association of the Pulp and Paper Industry Engineering Conference, TAPPI Press, Atlanta, GA, 1991, pp. 499–503.
- (7) J. R. Kearns, M. J. Johnson, and J. F. Grubb, "Accelerated Corrosion in Dissimilar Metal Crevices," Paper No. 228, NACE CORROSION/86 Conference, March 17–21, Houston, TX, 1988.
- (8) Bergquist, A., "Influence of Time Between Grinding and Testing, When Crevice Corrosion Testing is Performed," Avesta Sheffield AB, Avesta, Sweden, Report No. RK96089 of Oct. 16, 1996.
- (9) Corbett, R. A., "Problems Utilizing ASTM G48 to Evaluate High-Alloy Stainless Steels," Paper No. 298, NACE CORROSION/92 Conference, April 26–May 1, Nashville, TN, 1992.
- (10) Streicher, M. A., "Development of Pitting Resistant Fe-Cr-Mo Alloys," *Corrosion*, Vol 30, No. 3, 1974, p. 7.
- (11) Renner, M., Heuber, U., Rockel, M. B., and Wallis, D., "Temperature as a Pitting and Crevice Corrosion Criterion in the Ferric Chloride Test," *Werkstoffe und Korrosion*, Vol. 37, 1986, p. 183.
- (12) Brigham, R. J., and Tozer, E. W., "Effect of Alloying on Pitting Resistance of 18 % Cr Austenitic Stainless Steels," *Corrosion*, Vol 30, No. 5, 1974, p 161.
- (13) Treseder, R. S., "Method MTI-2 for Laboratory Testing of Wrought Iron- and Nickel-Base Alloys for Relative Resistance to Crevice Corrosion in a Standard Ferric Chloride Solution," *MTI Manual No. 3*, The Materials Technology Institute of the Chemical Process Industries, Inc., 1980, pp. 16–27.
- (14) Hibner, E. L., "Modification of Critical Crevice Temperature Test Procedures for Nickel Alloys in a Ferric Chloride Environment," *Materials Performance*, Vol 26, No. 3, 1987, p. 37.
- (15) Dundas, H. J., and Bond, A. J., "Corrosion Resistance of Stainless Steels in Seawater," Paper No. 206, NACE CORROSION/85 Conference, March 25–27, Boston, MA, 1985.
- (16) Bringham, R. J., "Temperature as a Crevice Corrosion Criterion," *Corrosion*, Vol 30, No. 11, 1974, p. 396.
- (17) Dean, S.W., "Research Report on Interlaboratory Test Program Results for ASTM G48 Standard Test Method for Pitting and Crevice Corrosion Resistance of Stainless Steels and Related Alloys by Use of the Ferric Chloride Solution - Methods E and F," February 1, 2002.

ASTM International takes no position respecting the validity of any patent rights asserted in connection with any item mentioned in this standard. Users of this standard are expressly advised that determination of the validity of any such patent rights, and the risk of infringement of such rights, are entirely their own responsibility.

This standard is subject to revision at any time by the responsible technical committee and must be reviewed every five years and if not revised, either reapproved or withdrawn. Your comments are invited either for revision of this standard or for additional standards and should be addressed to ASTM International Headquarters. Your comments will receive careful consideration at a meeting of the responsible technical committee, which you may attend. If you feel that your comments have not received a fair hearing you should make your views known to the ASTM Committee on Standards, at the address shown below.

This standard is copyrighted by ASTM International, 100 Barr Harbor Drive, PO Box C700, West Conshohocken, PA 19428-2959, United States. Individual reprints (single or multiple copies) of this standard may be obtained by contacting ASTM at the above address or at 610-832-9585 (phone), 610-832-9555 (fax), or service@astm.org (e-mail); or through the ASTM website (www.astm.org).